

# Flare Valve: A Detailed Exploration of Their Role in Ensuring Sustainable and Safe Flaring Practices

PABLO SANCHIS LAHIGUERA

Bachelor's thesis in industrial engineering  
Bergen, Norway 2023



Høgskulen  
på Vestlandet





# Flare Valve: A Detailed Exploration of Their Role in Ensuring Sustainable and Safe Flaring Practices

Pablo Sanchis Lahiguera

Department of Mechanical- and Marine Engineering  
Western Norway University of Applied Sciences  
NO-5063 Bergen, Norway

Høgskulen på Vestlandet  
Avdeling for ingeniør- og økonomifag  
Institutt for maskin- og marinfag  
Inndalsveien 28,  
NO-5063 Bergen, Norge

© Fornavn1 Etternavn1 Fornavn2 Etternavn2 ÅR / Eller bedrift

*Norsk tittel:*

En omfattende studie av funksjonaliteten og effektiviteten til fakkelfentilsystemer for bærekraftig falkingspraksis i olje- og gassindustrien

Author(s), student number: Pablo Sanchis Lahiguera 673705

Study program: Industrial engineering  
Date: June 2023  
Report number: IMM ÅR-MXX (X: Gruppe ID.nr)  
Supervisor at HiB: Maneesh Singh  
Assigned by: MRC Global  
Contact person: Simon Jeeves

Antall filer levert digitalt: 1



# ABSTRACT

The global oil and gas industry, a cornerstone of the world's economy, is continuously evolving to meet the rising demands for safer and more sustainable operations. A critical component of this progression is the flaring process, an operation integral to the overall safety and environmental considerations of industry practices. Within this process, one component, in particular, stands out due to its vital importance – the flare valve. This doctoral thesis presents a comprehensive exploration of flare valves, aiming to demystify their design, operation, and integration within the broader flaring system, while underscoring their role in sustainable and safe flaring practices.

Flare valves, also known as Fast Opening Valves (FOV) or Blow Down Valves (BDV), are instrumental in the rapid depressurization of plant facilities. Their swift action prevents catastrophic failure in the face of unexpected pressure surges, thereby acting as a crucial safety measure. Notably, what sets them apart from traditional BDVs is their distinctive "fail-open" function. This feature enables them to operate in a manner opposite to Emergency Shut Down Valves (ESV), which are designed to close in emergencies. Instead, flare valves automatically open to swiftly release pressure, preventing dangerous accumulation within the system.

The thesis delves into the intricacies of flare valves, examining their various components such as ball valves, axial flow valves, and rupture disks. By understanding these elements, the research sheds light on the underlying mechanisms that enable flare valves to perform their critical function. The force exerted during their fail-open action is immense, particularly in larger valves, often exceeding 100 tons. This rapid, forceful action serves as the last line of defense, safeguarding the plant and its personnel from potential disasters.

Moreover, the research investigates the concept of Safety Instrumented Functions (SIF), specifically in relation to flare valves. This study evaluates how these SIFs are managed during operations and the implications of their failure. An integral part of this analysis involves understanding the transition between on-demand and continuous demand, as this shift can significantly influence the performance, maintenance needs, and overall effectiveness of the flare valve systems.

The ultimate goal of this doctoral research is to enhance the understanding of flare valve systems and their critical role in sustainable flaring practices within the oil and gas industry. By providing an in-depth analysis of their design, operation, and integration, this thesis contributes to the broader discourse on safety, sustainability, and effective management of critical components in the industry. Furthermore, it underlines the importance of comprehensive understanding and meticulous management of safety-critical components like the flare valve, emphasizing their vital role in preventing potential disasters in the oil and gas industry.



# ACKNOWLEDGEMENTS

This thesis is submitted as a partial fulfilment of the requirements for the degree of industrial technology engineering polytechnic university of Valencia (UPV).

The work presented was conducted at MRC Global Office, in the period between february and May 2023.

I would like to give my thanks to my supervisors, Dr Maneesh Singh (DNV) for his guidance and support along the way.

Also, I would like to express my thanks to Simon Jeeves, General manager in the MRC Global group, Thanks you for his dedication and patience in all phases of the thesis. I have felt super comfortable and integrated.



# TABLE OF CONTENTS

ABSTRACT .....	6
ACKNOWLEDGEMENTS .....	8
TABLE OF CONTENTS .....	9
Chapter 1 Introduction.....	12
1.1 Background .....	12
1.2 Aim of Thesis .....	12
1.3 Scope of work.....	12
1.4 Limitations .....	13
1.5 Structure of thesis.....	13
1.6 Abbreviations .....	14
Chapter 2 Introduction of the concept of flaring .....	15
2.1 Introduction .....	15
2.2 Parts and components.....	15
2.3 Enviromental and safety considerations.....	17
Chapter 3 introduction to valves .....	19
3.1 Introduction .....	19
3.1.1 The Fundamental Role of Valves.....	19
3.2 Structure of a Valve.....	20
3.3 Types of Valves.....	20
3.4 qualities of a valve.....	22
3.5 Correct flaring valve selection.....	23
Chapter 4 Flare Valve Systems: Components and Functionality .....	26
4.1. Flare valves (ball valves and axial flow valves).....	26
4.2. Rupture disks.....	28
4.3. Integration in a flaring system.....	30
4.5. Valve materials and construction .....	31
4.5.1. Valve Materials .....	31
4.5.2. Construction Methods and Design Considerations .....	32

Chapter 5 The Necessity of Fast Opening Valves (FOV) in Flaring Operations .....	34
5.1. Introduction .....	34
5.1.1. Design Features of FOV Valves.....	35
5.1.2. Operating Principles of FOV Valves.....	35
5.2. Response time .....	36
5.3. Factors affecting performance.....	37
5.4. Fail action: Fail Open .....	38
Chapter 6 Fail Action Functionality and Failure Modes .....	40
6.1. Reasons for increased response time.....	40
6.2. Fail action mode: Importance and setup.....	40
6.2.1 Importance of Fail Action Mode .....	40
6.3. Consequences of not meeting response time or failure to respond .....	41
6.4. Common failure modes and their causes.....	42
6.4.1 Mechanical Failures .....	42
6.4.2 Control System Failures .....	42
6.5. Mitigation and prevention strategies .....	42
6.6 practical example of the safety of a real flaring valve.....	43
6.6.1 brief summary of the sensors.....	44
6.6.2 interpret the information.....	45
Chapter 7 FOV as a Safety Instrumented Function (SIF) .....	47
7.1. Definition and implications of SIF.....	47
7.1.1 Implications of SIF in Flare Valve Systems.....	47
7.2. Managing SIF during operations: Diagnostics and condition monitoring .....	48
7.2.1 Diagnostics .....	48
7.2.2 Condition Monitoring.....	48
7.3. Performance metrics and indicators .....	48
7.4. Safety integrity level (SIL) classification.....	49
7.5. Compliance with industry standards .....	50
Chapter 8 Advanced Diagnostics and Predictive Maintenance.....	52
8.1. Predictive Maintenance Overview .....	52
8.2. Role of Advanced Diagnostics in Predictive Maintenance .....	52

8.3. Benefits of Predictive Maintenance for Flare Valve Systems.....	52
8.4.Real Case Studies of Predictive Maintenance in the Oil and Gas Industry.....	53
8.5. The Future of Predictive Maintenance .....	55
Chapter 9 Sustainable Flaring Practices and Technological Advancements.....	56
9.1. Emission reduction techniques .....	56
9.2. Improvements in flare valve design .....	56
9.3. Alternative technologies and solutions.....	57
9.4. Regulatory and industry standards .....	58
9.5 real study of the reduction of emissions in a flaring valve.....	59
10. Conclusions .....	61
11. References .....	63

# Chapter 1 Introduction

## 1.1 Background

The oil and gas industry, a critical pillar of the global economy, is persistently striving towards sustainable and safe operations. An integral part of this endeavor is the flaring process, which plays a crucial role. Despite its ubiquity and importance, the mechanisms and components involved in the flaring process often remain overlooked. This thesis aims to make an in-depth study of one such pivotal component - the Flare Valve - contributing to the broader understanding of sustainable flaring practices.

Flare valves, interchangeably referred to as BDV or FOV, have a cardinal function in the flaring system. They ensure rapid depressurization of the plant, preventing catastrophic failure in the face of unexpected pressure surges. Despite their vital role, they are not actually Blow Down valves, although they serve a similar purpose. What distinguishes them from the traditional BDV is their "Fail Open" function, a distinctive feature that positions them as safety-critical components in the oil and gas infrastructure.

While Emergency Shut Down Valves (ESV) are designed to close in case of an emergency, flare valves operate in the opposite manner, automatically opening to swiftly release pressure. This fail-open mode is a safety-critical function that prevents dangerous build-up of pressure within the system. Furthermore, the moniker 'Fast Opening Valve' is derived from their swift response time - typically within two seconds - which is a crucial factor in mitigating potential risks.

The force exerted during this fail-open action is immense, particularly in larger valves, often exceeding 100 tons. This rapid, forceful action serves as the last line of defense, safeguarding the plant and its personnel from potential disasters. This thesis aims to delve into the intricacies of these vital components, exploring their design, operation, and integration into the flaring system, while also examining their role in sustainable and safe flaring practices.

In doing so, it aspires to contribute to the broader discourse on safety and sustainability within the oil and gas industry, highlighting the importance of comprehensive understanding and effective management of safety-critical components like the flare valve.

## 1.2 Aim of Thesis

The aim of this research is to provide a comprehensive understanding of the role and functionality of flare valves within the oil and gas industry's flaring systems. It intends to delve into the mechanisms that enable rapid response times and the fail-open feature, assessing their implications in risk mitigation and operational safety. Furthermore, this thesis will explore the potential of flare valves to enhance sustainability in flaring practices and identify avenues for future developments.

## 1.3 Scope of work

The scope of this work encompasses an examination of flare valves' operational mechanics and design. It will evaluate the integration of these valves within broader flaring systems and their contribution to sustainable practices. Additionally, the research will investigate the reasons and consequences of common failure modes, focusing on the fail-open feature and its importance in the industry.

## 1.4 Limitations

Due to logistical constraints, it will not be possible to physically visit a flaring plant, therefore, the study and descriptions will be conducted using literature and resources available. However, for the valve component, testing and analysis will be conducted on a similar valve supplied by MRC Global.

## 1.5 Structure of thesis

Chapter number	Chapter Title	Brief description
1	Introduction	This chapter provides an overview of the thesis, including background, aim, scope, and structure of the research study.
2	Introduction to the Concept of Flaring	It discusses flaring basics, including its parts, components, and environmental and safety considerations, along with regulations and guidelines.
3	Introduction to Valves	An introduction to the different types of valves, their inherent qualities, and their role in various industrial applications.
4	Flare Valve Systems: Components and Functionality	Comprehensive exploration of flare valves and rupture disks, their roles in a flaring system, system design, and integration considerations.
5	FOV Valve (Fast Opening Valve) Characteristics	It explores the design and operating principles of FOV valves, their rapid response time, and factors affecting their performance.
6	Fail Action Functionality and Failure Modes	This chapter delves into understanding failure modes, their causes, and mitigation strategies, with a special focus on fail action functionality.
7	FOV as a Safety Instrumented Function (SIF)	Discussion on the concept of SIF, its implications in flare valve systems, diagnostics, condition monitoring, and compliance with industry standards.
8	Advanced Diagnostics and Predictive Maintenance	Study of the potential of these technologies in managing and optimizing flare valve systems, ensuring their efficient and safe operation..
9	Sustainable Flaring Practices and Technological Advancements	Examination of emission reduction techniques, advancements in flare valve design, alternative technologies, and compliance with industry standards.

## 1.6 Abbreviations

FOV	Fast opening valve
BDV	Blow Down Valve
ESV	Emergency Shut Down Valve
SIF	Safety Instrumented Functions
SIL	Safety Integrity Level
CO <sub>2</sub>	Carbon Dioxide
CH <sub>4</sub>	Methane
VOCs	Volatile Organic Compounds
SIS	Safety Instrumented System
PFD	Probability of Failure on Demand
LOPA	Layer of Protection Analysis
KPIs	Key Performance Indicators
IEC	International Electrotechnical Commission
API	American Petroleum Institute
FCCU	Fluid Catalytic Cracking Unit
LNG	Liquefied Natural Gas
CNG	Compressed Natural Gas
EPA	Environmental Protection Agency
ZRF	Zero Routine Flaring
CFR	Code of Federal Regulations

# Chapter 2 Introduction of the concept of flaring

## 2.1 Introduction

The process of flaring, a prevalent practice in the oil and gas industry, involves the burning of excess and unwanted gases during extraction and processing. Flaring plays an integral role in safety management, as it functions to relieve pressure during unplanned over-pressuring of plant equipment. This procedure, while crucial for operational safety, also serves as a mechanism for waste gas disposal, mitigating the release of raw hydrocarbons into the environment.

However, despite these benefits, flaring has raised concerns due to its contribution to carbon emissions, thus necessitating a comprehensive understanding and implementation of sustainable flaring practices. The following sections delve deeper into the components, environmental and safety implications, and the regulations governing flaring, thereby highlighting the importance of flare valve systems in promoting safety and sustainability in the oil and gas industry.



FIGURE 2-1: FLARING FLAME

## 2.2 Parts and components

A flaring system plays a vital role in many industrial operations, especially within the oil and gas industry. This system, by safely burning off unwanted gas, ensures operational safety and environmental compliance. Understanding the components of a flaring system is crucial to ensuring its optimal function.

The most important components are the following:

- **The Flare Stack:**  
The flare stack is the most visible part of a flaring system. It's a tall structure, similar to a chimney, and serves as the exit point for gases being vented in a flaring operation. The height of the flare stack is designed to disperse the gases over a broad area to reduce potential hazards.
- **The Burner:**  
The burner, located at the top of the flare stack, is the component where the flaring gas is ignited. The design of the burner is critical in ensuring that the flaring process is efficient and that combustion is as complete as possible to minimize the release of harmful compounds.
- **Flare Tip:**  
The flare tip is the component at the end of the flare stack where the gas is released. The design of the flare tip can influence the noise and radiation levels of the flaring operation.
- **Seals and Seal Drum:**  
Seals and the seal drum play a significant role in the flaring system. The seal drum provides a liquid barrier that prevents the flashback of the flame into the stack, which could lead to catastrophic results. The seals ensure that the gas does not escape before it reaches the flare tip.
- **Knock-Out Drum:**  
The knock-out drum is another vital component in a flaring system. It is designed to remove any liquid droplets that may be carried along with the gas before the gas reaches the flare stack. This helps prevent the clogging of the flare tip and ensures efficient combustion.
- **Pilot and Ignition System:**  
The pilot and ignition system are essential components that ensure the gas is ignited reliably. The pilot is a smaller flame that burns continuously and ignites the main gas stream. The ignition system provides the spark to light the pilot.
- **Ejectors and Air Blower:**  
Ejectors and the air blower are components that help ensure the flaring process is efficient and safe. The ejectors help to mix the waste gas with air to improve combustion, while the air blower provides the necessary air flow.
- **Pressure Control Valve:**  
The pressure control valve is a safety device in the flaring system. It helps regulate the pressure of the gas being sent to the flare, preventing potential overpressure scenarios. This is the main component of this thesis and later we will go into detail about its possible types, qualities and components.



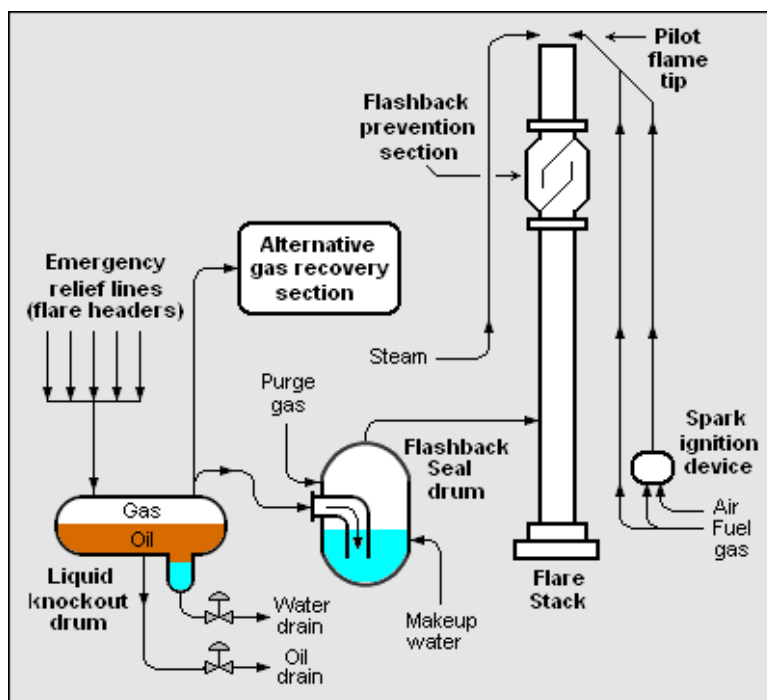

FIGURE 2-2: FLARING COMPONENTS (REFERENCE)

## 2.3 Environmental and safety considerations

Flaring systems, while instrumental in maintaining the safe operation of oil and gas facilities, have significant environmental and safety considerations that must be thoroughly addressed.

### Environmental Considerations :

The most pressing environmental issue related to flaring is the release of greenhouse gases, primarily carbon dioxide (CO<sub>2</sub>) and methane (CH<sub>4</sub>), which contribute to global warming. Furthermore, incomplete combustion during flaring can lead to the emission of volatile organic compounds (VOCs) and harmful particulates, impacting air quality and posing potential health risks.

Moreover, noise pollution is a concern in areas proximate to flaring operations, affecting both human and wildlife populations. Light pollution is another aspect, which can disrupt the local ecosystem, particularly nocturnal species.

### Safety Considerations:

Safety considerations in flaring operations are paramount. The primary safety function of a flare system is to burn off flammable gas released by the pressure relief valve during unplanned over-pressuring of plant equipment. The flaring system is designed to prevent dangerous overpressure, which could lead to equipment failure and potentially catastrophic explosions

Flare systems also need to be designed and operated to prevent flame lift-off or blow-out, which could lead to unburned hydrocarbons being released. Regular maintenance and inspection are crucial to ensure the reliability of flare systems and reduce the risk of equipment malfunction.

Finally, occupational safety measures must be taken into account, protecting personnel working in proximity to flaring operations from potential hazards such as heat stress, noise exposure, and harmful emissions.

Thus, sustainable flaring practices must consider both the environmental implications and the safety of personnel and surrounding communities, underscoring the importance of efficient and reliable system design, operation, and maintenance.

# Chapter 3 introduction to valves

## 3.1 Introduction

Valves are integral elements of any industrial process, acting as regulators of fluid flow and pressure within a system. The oil and gas industry, with its complex networks of pipelines and equipment, is no exception. With a focus on flare valve systems, this chapter aims to lay a solid foundation on the general concept of valves, their functionality, and importance.

### 3.1.1 The Fundamental Role of Valves

In a nutshell, a valve controls the flow of fluids (liquids, gases, fluidized solids, or slurries) by opening, closing, or partially obstructing various passageways. In the context of flare systems in the oil and gas industry, valves play a critical role in ensuring system integrity, maintaining operational efficiency, and upholding safety standards. They are used to regulate the release of excess pressure and unwanted gases, thus mitigating potential risks associated with pressure build-up and hazardous gas emissions.

Different types of valves are available, each designed for specific functionalities based on the requirements of the system. For instance, ball valves and axial flow valves are commonly used in flare systems due to their quick response time and reliable operation. The ball valve, noted for its spherical closure unit, offers tight shutoff and control over fluid flow. In contrast, the axial flow valve, characterized by a streamlined flow path, ensures minimal pressure drop and is typically employed in high-pressure systems.

Another key component in flare systems is the rupture disk, a type of pressure relief device that provides overpressure protection. These devices burst when the system pressure exceeds a pre-defined threshold, thereby serving as a fail-safe mechanism.

In the chapters that follow, we will delve deeper into the specific role of these valves and devices within flare systems, examining their design, functionality, and impact on the overall operation and sustainability of flaring practices in the oil and gas industry..

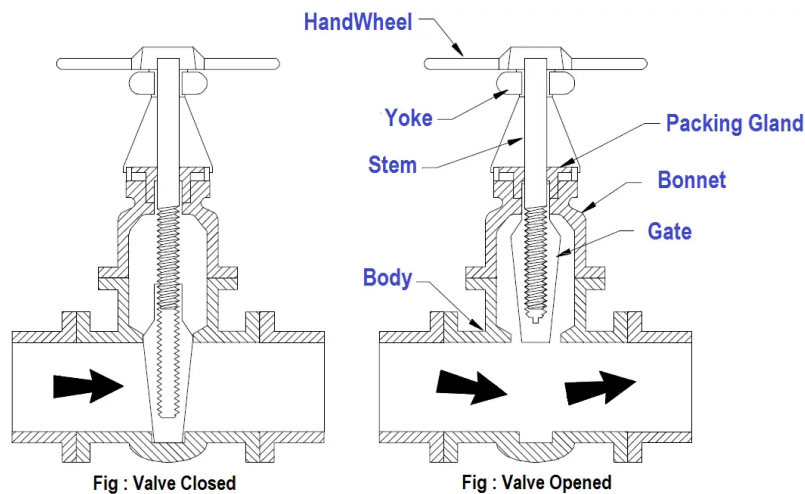

FIGURE 3-1 DIAGRAM OF A BASIC VALVE MECHANISM

## 3.2 Structure of a Valve

The components common that we could find in the structure of most valves, as can be seen in figure 3-1, would be the following:

**Body:** The body, sometimes called the shell, is the primary pressure boundary of a valve. It serves as the principal element of a valve assembly because it is the framework that holds everything together. The body resists fluid pressure loads from connecting piping and receives inlet and outlet piping through threaded, bolted, or welded joints. Valve bodies are usually cast or forged into a variety of shapes to accommodate the specific requirements of the valve.

**Bonnet:** The bonnet is the cover for the opening in the valve body. It serves as the second principal pressure boundary of a valve and is usually cast or forged of the same material as the body. The bonnet is connected to the body by a threaded, bolted, or welded joint. In some designs, the bonnet also supports valve internals and accessories such as the stem, disk, and actuator.

**Trim:** The trim refers to the internal elements of a valve, typically including a disk, seat, stem, and sleeves needed to guide the stem. The performance of a valve is determined by the disk and seat interface and the relation of the disk position to the seat. The trim makes basic motions and flow control possible.

- **Disk:** The disk is the third primary principal pressure boundary. It provides the capability for permitting and prohibiting fluid flow. Disks are typically forged and, in some designs, hard-surfaced to provide good wear characteristics. Most valves are named, in part, according to the design of their disks.
- **Seat:** The seat or seal rings provide the seating surface for the disk. In some designs, the body is machined to serve as the seating surface and seal rings are not used. In other designs, forged seal rings are threaded or welded to the body to provide the seating surface. Seal rings are not usually considered pressure boundary parts because the body has sufficient wall thickness to withstand design pressure without relying upon the thickness of the seal rings.
- **Stem:** The stem connects the actuator and disk, and is responsible for positioning the disk. Stems are typically forged and connected to the disk by threaded or welded joints.

**Actuator:** An actuator in a valve is the component that converts energy into motion to open or close the valve. This energy may be manual (as in a hand wheel or lever), electric, pneumatic (air pressure), or hydraulic (fluid pressure). The type of actuator used can depend on the size of the valve, the required speed of operation, the number of operations (cycles) required over time, the availability of power sources, and many other factors. Actuators can be as simple as levers to manually open or close a valve, or they can be complex electrically operated actuators for process control in industrial applications.

**Packing:** Packing is used to provide a seal between the valve body and the stem. This is necessary to prevent process fluid from leaking out of the valve during operation. The packing material needs to be resistant to the process fluid, be able to withstand the operating temperatures and pressures, and provide a reliable seal around the moving stem.

## 3.3 Types of Valves

Valves are available in a diverse array of designs and configurations to cater to the specific needs of various industrial applications. This section provides an overview of the most common types of valves employed in the oil and gas industry, highlighting their unique features, advantages, and limitations.

- **Gate Valve:** The gate valve is a versatile and robust piece of equipment widely used across many industrial applications. Built from Inconel sheet, recognized for its strength and resilience, the gate valve employs a rising or falling wedge-shaped gate to control fluid flow. This design provides complete shutoff capabilities with minimal pressure loss when fully closed, making it

perfect for high-pressure applications like waterworks, oil pipelines, and landscape irrigation systems.

- **Globe Valve:** Globe valves have broad usage due to their fluid or gas flow adjustment capability. Manufactured using an Inconel sheet capable of withstanding extreme temperatures and high pressure, these valves are integral to industrial processes requiring proper containment and pressure control. Globe valves find applications in regulating steam and water flow, isolating line sections for maintenance or repairs, and facilitating transport through slow volume changes with low-pressure losses.
- **Check Valve:** Check valves maintain a balanced flow in different systems. Constructed from Inconel sheet for its strength and chemical resistance, these valves allow for one-way flow, preventing backward movement of liquids or gases into areas where they shouldn't be. Check valves are useful with pressure relief systems to ensure safety while efficiently controlling pressure and gas flow.
- **Plug Valve:** Plug valves are versatile and reliable devices that stop, start, and control fluid flow. They utilize a tapered or cylindrical plug turned 90 degrees to seal the inlet or outlet port. Constructed from materials like Inconel sheet, brass, aluminum, and stainless steel, plug valves are ideal for high-temperature applications where safety, efficiency, and reliability are paramount, such as refineries and pipelines.
- **Ball Valve:** Ball valves are common in many industrial applications. They use a hollow, spherical-shaped Inconel sheet to shut off the flow of materials like fluids, gases, and other hazardous mixtures. With solid Inconel sheet construction providing excellent corrosion resistance, ball valves are ideal for critical environments like processing plants and wastewater treatment facilities. They're also used in residential and commercial projects, including pipes, drain lines, air conditioning systems, and water heaters.
- **Butterfly Valve:** Butterfly valves regulate flow in any piping system, featuring a rotating disc attached to an Inconel sheet to control flow direction, pressure, and rate. They're used in industries such as water treatment and chemical/petrochemical plants, where quick decisions are crucial. Butterfly valves are also common in HVAC systems, which require fast response times during temperature changes or air ventilation adjustments.
- **Needle Valve:** Needle valves are commonly used to control the flow of materials in a variety of industries. They are especially efficient when handling high-pressure liquids or gases in process piping systems. Some needle valves are made with Inconel sheets for added strength and heat resistance, making them suitable for use in steam distribution systems and nuclear reactors.
- **Pinch Valve:** Pinch valves are unique tools used in many applications. Constructed from Inconel sheet material, they offer flexibility, corrosion resistance, and a long lifespan. Pinch valves are installed on pipes carrying pressurized fluids or gases, with the Inconel sheet material preventing corrosion for reliable operation over time. These valves serve various purposes, such as regulating flow rate, isolating systems, stopping fluid flow, and controlling pressure more accurately than traditional valve options.
- **Pressure Relief Valve:** Pressure relief valves are essential safety features in machinery and equipment. They control system pressure to reduce the risk of damage to machines and other components. Made from high-grade Inconel sheets, these valves offer superior durability and heat resistance, making them capable of handling extreme temperatures and pressures. Pressure

relief valves are crucial in various industries, used in equipment ranging from boilers to gas tanks, to ensure safe operation and protect both employees and machinery.

Each type of valve offers distinct advantages and drawbacks, necessitating a careful assessment of system requirements to select the appropriate valve for a specific application. The subsequent sections will focus on the critical role of ball valves, axial flow valves, and rupture disks in flare valve systems, exploring their specific functionalities and implications for sustainable flaring practices in the oil and gas industry.

### 3.4 qualities of a valve

The functionality of valves in flaring systems is integral to the safety and efficiency of oil and gas operations. These devices are defined by several key qualities, including durability and resilience, operational efficiency, safety and reliability, ease of maintenance, and regulatory compliance.

- **Durability and Resilience:**

Durability and resilience are crucial traits for a valve operating within the high-pressure, high-temperature, and corrosive environment of a flaring system. Valves need to withstand the rigours of such conditions over extended periods, with materials like stainless steel and certain plastic polymers often chosen for their inherent durability. The valve's resilience, particularly in moving components such as the stem, directly impacts its lifespan and operational efficiency.

- **Operational Efficiency:**

Operational efficiency in a valve refers to its ability to regulate flow accurately and respond swiftly to control inputs. In the context of a flare valve, precision is vital in maintaining desired flow rates, which contributes to the stability of the entire system. A valve's responsiveness, especially in FOVs, is critical in rapidly depressurizing the plant when necessary.

- **Safety and Reliability:**

Valves play a significant role in the safety of oil and gas operations. Reliable valve operation helps prevent potential accidents and system failures. The ability of a valve to function as expected under all operational conditions contributes to its reliability. This quality is particularly important for safety-critical components such as the FOV, where a delay or failure could lead to catastrophic results.

- **Ease of Maintenance:**

Maintenance-friendly design is a vital quality of a valve. Valves require regular inspection, cleaning, and potential repair or replacement to ensure their optimal operation. A valve designed with ease of maintenance in mind can reduce downtime, enhance operational efficiency, and potentially decrease overall maintenance costs.

- **Regulatory Compliance:**

Lastly, a valve's compliance with industry standards and regulations is a crucial quality. These standards ensure that valves meet specific safety, environmental, and operational requirements. Compliance reduces the risk of operational failures, legal implications, and enhances the overall safety and sustainability of the oil and gas operation.

### 3.5 Correct flaring valve selection

In the wake of unraveling the different types of valves and their diverse characteristics in the preceding sections, the focus now shifts towards the critical task of selecting the most appropriate valve for flaring systems. This selection is paramount to the successful operation of these systems, with the chosen valve being responsible for managing pressure, ensuring safety, and ultimately contributing to the efficiency and sustainability of the plant.

A fundamental approach to this selection involves quantifying the importance of various valve characteristics, assigning a score from 1 to 5, with 1 being the least important and 5 being of the utmost importance. The scores allocated are directly proportional to the relevance of these attributes to flaring applications. The essential characteristics are defined as follows:

Quality	Score
Durability and Resilience	5
Operational Efficiency	4
Safety and Reliability	5
Ease of Maintenance	3
Regulatory Compliance	4

Upon careful evaluation, we can then assign a performance score from 1 to 10 to each type of valve, based on how well they fulfill these characteristics.

Type	Score				
	Durability and Resilience	Operational Efficiency	Safety and Reliability	Ease of Maintenance	Regulatory Compliance
Gate Valve	7	6	7	6	8
Globe Valve	8	7	8	7	8
Check Valve	6	7	8	5	8
Plug Valve	7	6	7	7	8
Ball Valve	8	9	8	8	8
Butterfly Valve	7	8	7	8	8
Needle Valve	8	7	8	7	8
Pinch Valve	6	5	7	8	7

#### Explanation of Ratings:

- Gate Valve:** These valves are durable and resilient due to their simple design, but their operational efficiency is somewhat lower due to the time it takes to open and close. Maintenance can be somewhat challenging, especially for larger valves, and their safety and reliability are generally good. They are widely used in various industries and comply with many regulations.

- **Globe Valve:** Globe valves are highly durable and offer good operational efficiency. They are safe, reliable, and relatively easy to maintain. They are also widely used and comply with many regulations.
- **Check Valve:** Check valves are generally durable and efficient, but maintenance can be difficult due to their design. They are very reliable and safe because they prevent backflow. They also comply with many regulations.
- **Plug Valve:** Plug valves are fairly durable and offer average operational efficiency. They are reliable and safe, but maintenance can be somewhat difficult due to their design. They comply with many regulations.
- **Ball Valve:** Ball valves are very durable and highly efficient. They offer good safety and reliability and are relatively easy to maintain. They are widely used and comply with many regulations.
- **Butterfly Valve:** Butterfly valves are quite durable and offer high operational efficiency. They are reliable and safe, and their simple design makes maintenance relatively easy. They comply with many regulations.
- **Needle Valve:** Needle valves are highly durable and offer good operational efficiency. They are very reliable and safe, and maintenance is relatively straightforward. They comply with many regulations.
- **Pinch Valve:** Pinch valves are somewhat less durable due to their design, and their operational efficiency is average. They are fairly reliable and safe, and their design makes maintenance relatively easy. They comply with many regulations but are not as widely used as some other types of valves.

By multiplying the importance score with the performance score, we can create an aggregate score that can guide the selection process.

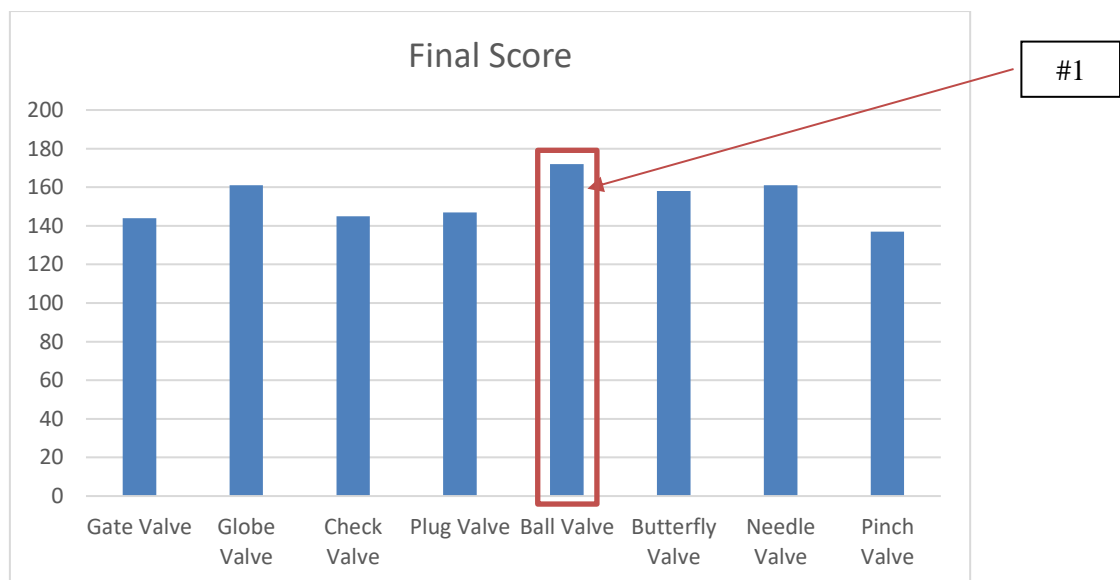

For instance, in the case of a Ball Valve, considering its high durability, exceptional operational efficiency, low maintenance requirements, and excellent safety and reliability, coupled with strict adherence to regulatory compliance, the overall score is impressively high.



After calculating these aggregate scores for all valve types, it becomes apparent that the Ball Valve emerges as the most suitable choice for flaring systems, boasting a remarkable aggregate score of 172. However, while these scores provide a quantitative basis for the selection process, it's crucial to remember that each application can have unique requirements. Therefore, a more in-depth analysis of the Ball Valve's attributes will be conducted in the succeeding chapter, to further substantiate its suitability for flaring systems.

# Chapter 4 Flare Valve Systems: Components and Functionality

## 4.1. Flare valves (ball valves and axial flow valves)

In order for flaring systems to operate safely and effectively, flare valves are essential. These valves regulate the gas flow to the flare and provide correct depressurization. Ball valves and axial flow valves are the two primary types of flare valves. The design, functionality, benefits, and drawbacks of each type will be thoroughly explored in this section.

**Ball Valve:** A popular variety of flare valve that is renowned for its reliability and durability is the ball valve. They are composed of a rotating, spherical closure element (the ball) with a flow path running through its center.

The valve is open when the ball is in line with the flow path, and closed when it is perpendicular to the flow path. Typically, ball valves are opened and closed manually or by electric, pneumatic, or hydraulic actuators.

Advantages	disadvantages
<ul style="list-style-type: none"> <li>• They are quick to open and close because the transition between the open and closed positions generally only requires a quarter turn.</li> </ul>	<ul style="list-style-type: none"> <li>• They can cost more than other types of valves because of their complex manufacturing and design processes.</li> </ul>
<ul style="list-style-type: none"> <li>• They have High sealing performance, which reduces the possibility of leaks and guarantees safe operation.</li> </ul>	<ul style="list-style-type: none"> <li>• the potential for erosion or cavitation, especially in high-pressure or high-speed applications, could eventually harm the valve's components.</li> </ul>
<ul style="list-style-type: none"> <li>• They have Low pressure drop across the valve, which saves operational expenses and energy usage.</li> </ul>	<ul style="list-style-type: none"> <li>• They have limited flow control because they're more suited for on/off applications than precision flow management.</li> </ul>
<ul style="list-style-type: none"> <li>• Low maintenance needs since the ball's smooth surface minimizes wear and friction.</li> </ul>	

FIGURE 4-1 ADVANTAGES VS DISADVANTAGES OF THE BALL VALVE

**Axial Flow valves:** Axial flow valves, also known as axial check valves or axial check valves, are another common type of flare valve. These valves have a cylindrical closure element that moves along the central axis of the valve body, allowing precise control of airflow. Axial flow valves can be operated manually or by an actuator, similar to ball valves.

Advantages	disadvantages
<ul style="list-style-type: none"> <li>• Excellent flow control, as the linear movement of the closing element precisely regulates the air flow.</li> </ul>	<ul style="list-style-type: none"> <li>• Due to their complex design and moving parts, they can be more complicated and expensive to manufacture and maintain.</li> </ul>
<ul style="list-style-type: none"> <li>• The streamlined design minimizes turbulence and pressure drop across the valve, reducing the risk of cavitation and erosion.</li> </ul>	<ul style="list-style-type: none"> <li>• If the sealing surfaces are damaged or misaligned, leaks may occur that may require more frequent maintenance and inspection.</li> </ul>
<ul style="list-style-type: none"> <li>• Faster response time compared to other valve types, making it suitable for critical applications with strict safety requirements.</li> </ul>	<ul style="list-style-type: none"> <li>• Larger sizes have limited availability because their designs are more difficult to manufacture and operate on a larger scale.</li> </ul>
<ul style="list-style-type: none"> <li>• High pressure and high temperature properties allow them to be used in a variety of demanding applications.</li> </ul>	

FIGURE 4-2 ADVANTAGES VS DISADVANTAGES OF THE AXIAL FLOW VALVE

In summary, both ball valves and axial flow valves are important components of flare systems in the oil and gas industry, each with their own unique advantages and disadvantages. The selection of these two valve types depends on factors such as the

specific application, flow control requirements, pressure and temperature conditions, and budget constraints. A thorough understanding of the design, functions, and limitations of each valve type is essential to selecting the correct valve for a particular flare system and ensuring safe and efficient operation.



FIGURE 4-3 AXIAL FLOW VALVE



FIGURE 4-4 BALL VALVE

## 4.2. Rupture disks

Rupture disks, also known as bursting discs or pressure safety discs, are critical safety devices in flaring systems that protect equipment and personnel from overpressure situations. These non-reclosing pressure relief devices are designed to burst at a predetermined pressure, providing an additional layer of protection in case the primary pressure relief valve fails or is unable to manage the excess pressure. This section will provide a comprehensive overview of rupture disks, discussing their design, functionality, types, applications, and relevant considerations.

### Design and Functionality

A rupture disk is a thin, flat, circular membrane made of metal, graphite, or plastic materials. The disk is designed to withstand a specific pressure differential, known as the burst pressure, which is typically indicated by the manufacturer. When the system pressure exceeds the burst pressure, the disk ruptures, releasing the excess pressure and preventing potential damage to equipment and harm to personnel. The rupture disk is installed upstream of the primary pressure relief valve, such as a flare valve, and is often used in conjunction with this valve in a complementary manner.

### Types of Rupture Disks

There are several types of rupture disks, each with its design features and applications:

- **Forward-acting (tension-loaded) rupture disks:** These disks have a convex shape facing the process pressure, and they rupture when the tensile strength of the disk material is exceeded due to the applied pressure. Forward-acting rupture disks are simple in design and can be used in a wide range of applications.
- **Reverse-acting (compression-loaded) rupture disks:** In these disks, the concave side faces the process pressure, and they rupture when the applied pressure overcomes the compressive load provided by the disk's inherent design or an additional support structure. Reverse-acting rupture disks typically offer a longer service life and better resistance to pressure cycling.
- **Graphite rupture disks:** Made of graphite material, these rupture disks are designed to offer excellent chemical resistance and high-temperature capabilities. They are often used in corrosive or high-temperature environments where metal rupture disks may not be suitable.

### Applications and Considerations

Rupture disks are used in various industries, including oil and gas, chemical processing, pharmaceuticals, and power generation. They are employed to protect a wide range of equipment, such as pressure vessels, piping systems, and reactors. When selecting a rupture disk for a specific application, several factors should be considered, including:

- **Burst pressure:** The rupture disk should be designed to burst at a pressure that provides adequate protection for the system while minimizing the risk of premature failure.
- **Operating pressure:** The disk should be capable of withstanding the normal operating pressure of the system without rupturing.

- **Temperature:** The disk material and design should be suitable for the temperature range of the process.
- **Corrosion resistance:** The disk material should be compatible with the process media to ensure a long service life and reliable performance.
- **Installation and maintenance:** The rupture disk should be easy to install, inspect, and replace as needed.

### Limitations and Challenges

While rupture disks provide valuable protection in flaring systems, they also have some limitations and challenges:

- **One-time use:** Rupture disks are non-reclosing devices, meaning they need to be replaced after each activation. This can lead to downtime and additional maintenance costs.
- **Sensitivity to pressure cycling and temperature fluctuations:** Repeated pressure cycling and temperature changes can cause fatigue and premature failure of the rupture disk.
- **Inaccurate burst pressure:** Manufacturing tolerances and environmental factors can result in the actual burst pressure deviating from the specified value.

In conclusion, rupture disks are essential safety devices in flaring systems, offering an additional layer of protection in case of overpressure situations. They are available in various types and materials, making them suitable for a wide range of applications in the oil and gas industry and beyond. However, understanding their design, functionality, and limitations is crucial for selecting the appropriate rupture disk for a specific application and ensuring reliable performance. Proper installation, inspection, and maintenance are also key factors in maximizing the rupture disk's effectiveness and lifespan.

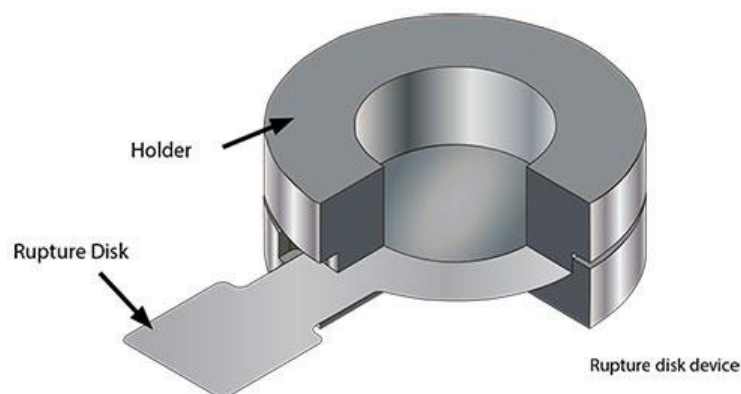

FIGURE 4-5 RUPTURE DISK

### 4.3. Integration in a flaring system

Integrating flare valves and rupture disks into a flaring system is a crucial aspect of ensuring the safe and efficient operation of the entire system. This section will discuss how these components are integrated into the flaring system, their roles within the system, and the factors to consider when designing and implementing the integration.

#### Role of Flare Valves and Rupture Disks in a Flaring System

In a flaring system, flare valves and rupture disks serve as critical safety components. The primary function of a flare valve is to control the flow of gases to the flare stack during normal and emergency operations. The valve can be quickly opened or closed, depending on the system's needs, to manage pressure and maintain safety. Rupture disks serve as a backup safety mechanism, designed to burst and release pressure in case the flare valve fails or is unable to handle the excess pressure effectively.

#### Configuration and Installation

Proper configuration and installation of flare valves and rupture disks are essential for effective system integration. Flare valves are typically installed on the main flare header, with the valve's inlet connected to the process stream and the outlet connected to the flare stack. Rupture disks are installed upstream of the flare valve, either in series with or parallel to the valve. In a series configuration, the rupture disk is installed directly upstream of the flare valve, providing an additional layer of protection. In a parallel configuration, the rupture disk is installed on a separate branch that bypasses the flare valve, providing an alternate flow path for pressure relief.

When installing flare valves and rupture disks, it is essential to consider factors such as proper orientation, sealing, and support. The orientation of the components should align with the flow direction, and adequate sealing should be ensured to prevent leaks. Proper support structures should be in place to prevent strain on the components and the associated piping.

#### Control and Monitoring Systems

Integrating control and monitoring systems with flare valves and rupture disks is essential for maintaining the safe operation of the flaring system. These systems can include sensors, actuators, and control panels, which allow operators to remotely open or close the flare valve, monitor the system pressure, and receive alerts in case of potential issues. Monitoring systems can also include diagnostic tools to assess the health and performance of the flare valve and detect potential failure modes before they become critical.

#### System Design and Integration Considerations

When designing and integrating flare valves and rupture disks into a flaring system, several factors should be considered to ensure optimal performance:

- **Compatibility:** The selected flare valves and rupture disks should be compatible with the process media, operating conditions, and system requirements.
- **Redundancy:** Ensuring redundancy in the system can help maintain safety in case of component failure. This can be achieved by installing multiple flare valves, rupture disks, or a combination of both.

- **Maintenance and Inspection:** The system should be designed to facilitate easy maintenance and inspection of the flare valves and rupture disks, minimizing downtime and ensuring reliable performance.
- **Regulatory Compliance:** The integration of flare valves and rupture disks should comply with relevant industry standards, regulations, and guidelines to ensure the safe and environmentally responsible operation of the flaring system.

In conclusion, proper integration of flare valves and rupture disks into a flaring system is essential for maintaining safety and efficiency. By considering factors such as configuration, installation, control and monitoring systems, and design considerations, operators can effectively integrate these critical components into their flaring systems and ensure reliable performance under various operating conditions.

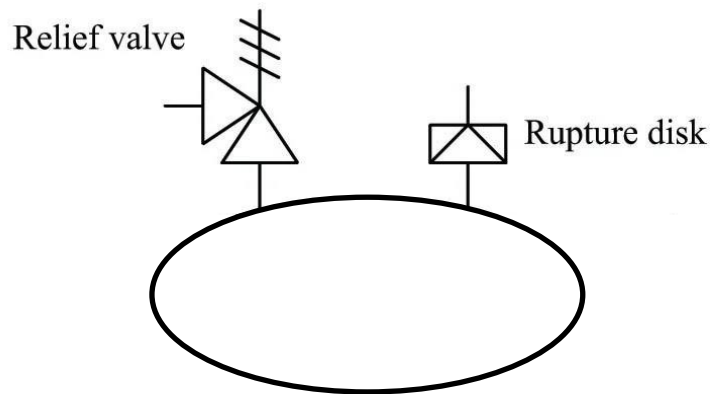

FIGURE 4-6 RUPTURE DISK + RELIEF VALVE

## 4.5. Valve materials and construction

The materials and construction of flare valves play a vital role in their performance, durability, and reliability within flaring systems in the oil and gas industry. This section will provide a detailed overview of the different materials used in flare valves, their properties, and the factors influencing the choice of material, as well as discussing the various construction methods and design considerations for these critical components.

### 4.5.1. Valve Materials

A variety of materials can be used in the construction of flare valves, each with specific properties that make them suitable for different applications, environments, and system requirements. Some of the most common materials used in flare valves include:

- **Carbon Steel:** Carbon steel is a widely used material in flare valves due to its excellent strength, durability, and cost-effectiveness. It is suitable for a range of applications and can withstand high pressure and temperature conditions. However, carbon steel is susceptible to corrosion, particularly in the presence of acidic or corrosive media, and may require additional protection or treatment.

- **Stainless Steel:** Stainless steel offers superior corrosion resistance compared to carbon steel, making it a popular choice for flare valves used in corrosive environments or with aggressive process media. There are various grades of stainless steel, each with specific properties and applications. For example, austenitic stainless steels (e.g., 316, 304) are commonly used due to their high corrosion resistance and good mechanical properties, while duplex stainless steels offer higher strength and resistance to stress corrosion cracking.
- **Alloy Steel:** Alloy steels are used in flare valves for their high strength, excellent corrosion resistance, and ability to withstand extreme temperature and pressure conditions. Common alloy steels used in flare valves include Chrome-Moly steels (e.g., A182 F11, F22) and Nickel-based alloys (e.g., Inconel, Hastelloy). These materials are typically more expensive than carbon or stainless steel but are necessary for demanding applications or severe service conditions.
- **Non-metallic Materials:** In some cases, non-metallic materials, such as polymers or ceramics, may be used in flare valve construction. These materials can offer advantages such as low weight, excellent corrosion resistance, and reduced friction. However, they are typically less robust than metallic materials and may have limited temperature and pressure capabilities.

#### 4.5.2. Construction Methods and Design Considerations

The construction methods and design of flare valves can significantly impact their performance, reliability, and service life. Some key aspects to consider when designing and constructing flare valves include:

- **Manufacturing Processes:** Flare valve components can be manufactured using various processes, such as casting, forging, or machining. The choice of manufacturing method depends on factors such as material properties, desired geometry, and production volume. Each method has its advantages and limitations, influencing the final quality, strength, and cost of the valve components.
- **Sealing Mechanisms:** The sealing mechanism is an essential aspect of flare valve design, as it ensures proper closure and prevents leaks. Different types of seals, such as metal-to-metal, soft-seated, or fire-safe designs, can be used depending on the application requirements, operating conditions, and material compatibility.
- **Actuation:** The choice of actuation method, whether manual, electric, pneumatic, or hydraulic, can impact the overall performance and reliability of the flare valve. Factors to consider when selecting an actuator include response time, available power sources, environmental conditions, and ease of maintenance.
- **Design Standards and Regulations:** Flare valve design and construction should adhere to relevant industry standards, codes, and regulations, such as API, ASME, and ISO, to ensure safety, reliability, and compatibility with other system components.

In conclusion, the materials and construction of flare valves are critical factors that influence their performance, durability, and reliability in flaring systems. By understanding the properties and characteristics of different valve materials, as well as considering the various construction methods and design aspects, engineers and operators can make informed decisions when selecting and designing flare valves for their specific applications. This knowledge helps ensure that the chosen flare valves are not only compatible with the process media and operating conditions but also provide long-lasting, safe, and efficient performance within the flaring system. Furthermore, adhering to relevant industry standards and regulations is essential to maintaining safe and reliable operations in the oil and gas industry.





# Chapter 5 The Necessity of Fast Opening Valves (FOV) in Flaring Operations

## 5.1. Introduction

When it comes to control valves, the inherent flow characteristic plays a pivotal role in defining the relationship between the 'valve opening' and the flow rate under constant pressure conditions. This is crucial to grasp as the 'valve opening' in this context refers to the relative position of the valve plug to its closed position against the valve seat, not the orifice pass area.

Let's examine three main types of control valves, namely fast opening, linear, and equal percentage, to understand their inherent characteristics and applications better.

- **Fast Opening Valves:** Fast opening valves are equipped with a valve plug that facilitates a considerable change in flow rate for a small valve lift from the closed position. For instance, a valve lift of 50% could result in an orifice pass area and flow rate up to 90% of its maximum potential. Interestingly, the exact shape of the fast opening curve is not defined in standards, and thus, two valves—one giving an 80% flow for a 50% lift and the other providing a 90% flow for a 60% lift—may both be regarded as having a fast opening characteristic. These valves are usually electrically or pneumatically actuated and are typically used for 'on/off' control.
- **Linear Valves:** In contrast, linear valves are designed such that the flow rate is directly proportional to the valve lift (H), at a constant differential pressure. This is achieved by having a linear relationship between the valve lift and the orifice pass area. For example, at 40% valve lift, a 40% orifice size allows 40% of the full flow to pass. Thus, linear valves are excellent for applications requiring a straightforward relationship between the valve lift and flow rate.
- **Equal Percentage Valves:** Equal percentage valves have a unique design wherein each increment in valve lift increases the flow rate by a certain percentage of the previous flow. This relationship between the valve lift and orifice size (and hence, flow rate) is logarithmic rather than linear. For example, for a valve with a rangeability of 50, every 10% increase in valve lift results in a 48% increase in flow rate. This makes equal percentage valves an excellent choice for applications needing a progressive increase in flow rate with valve lift.

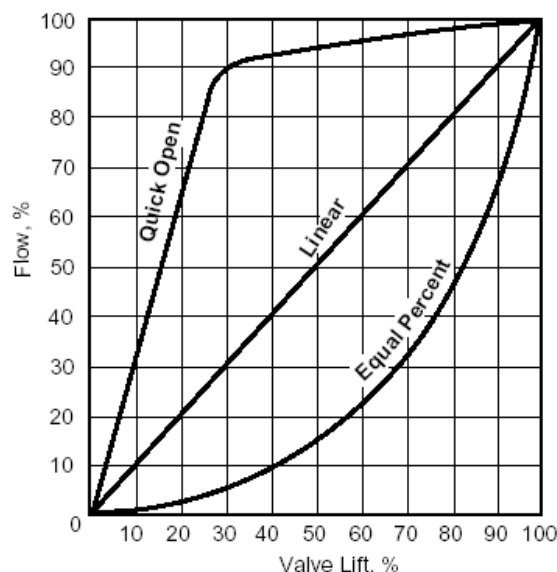

FIGURE 5-1 QUICK VS LINEAR VS EQUAL

## **Flaring Valve**

Flaring operations serve as a critical safety measure in numerous industries, predominantly in the gas and oil sector. These operations necessitate the use of valves that can respond rapidly to changing conditions, and this is where the importance of FOVs comes into play. In general, the valve must respond by opening in less than 2 seconds.

FOVs, or Quick Opening Valves, are distinguished by their distinctive flow characteristics, where they facilitate the maximum change in flow rate at low valve travels, maintaining a nearly linear relationship. This ability to initiate a swift change in flow rate is crucial in flaring operations, where unexpected pressure build-ups can lead to catastrophic consequences if not promptly relieved. The sudden release of pressure is made possible by the rapid action of the FOV, swiftly opening to allow the excess pressure to be vented out.

Furthermore, FOVs are commonly utilized in systems requiring 'instant' large flow, such as safety or cooling water systems. This attribute is precisely why they are indispensable in flaring operations. When a critical pressure threshold is reached, the FOV must open rapidly to allow a large volume of gas to be safely flared off, thus preventing any potential overpressure scenarios within the system.

In summary, the Fast-Opening Valve plays an integral role in flaring operations due to its ability to allow a swift and substantial change in flow rate, providing an efficient and effective means of pressure relief. By ensuring the quick venting of gases during flaring, FOVs contribute significantly to maintaining the safety and stability of industrial operations.

### **5.1.1. Design Features of FOV Valves**

FOV valves are designed with several features that enable their rapid response times and reliable operation. Some of these features include:

- Lightweight valve components, which reduce the inertia of the moving parts and allow for faster actuation.
- Optimized flow paths and valve trim geometry, which minimize pressure drops and ensure efficient flow of fluids through the valve.
- Robust sealing mechanisms, such as metal-to-metal seals, which provide a reliable seal even under extreme temperature and pressure conditions.
- Actuators designed for quick and precise movement, such as spring-loaded or high-speed pneumatic actuators.

### **5.1.2. Operating Principles of FOV Valves**

FOV valves operate based on the following principles:

- In normal operating conditions, the FOV valve remains closed, preventing the release of process fluids to the flare system.
- Upon the emergence of an urgent scenario, such as an abrupt surge in pressure or temperature, it becomes imperative for the FOV valve to promptly swing open, enabling the discharge of excess pressure, thereby safeguarding the facility against potential harm or disastrous collapse.

- The actuator, responding to a signal emitted by the plant's control apparatus, instigates the valve's unveiling. This impetus might manifest as an electrical, pneumatic, or hydraulic stimulus, contingent upon the actuator's unique design specifications.
- In a remarkably brief period, typically spanning no more than 2 seconds, the valve flings open, forging an instantaneous depressurization conduit for the process fluids coursing through it. This lightning-fast opening interval plays a pivotal role in circumventing damage to equipment while concurrently securing the safety of personnel present.
- Once the emergency situation is resolved, the FOV valve can be closed to restore normal operation. The valve's closing time may be slower than its opening time, as the primary focus is on rapid depressurization during emergencies.

## 5.2. Response time

FOV play a crucial role in the oil and gas industry, providing rapid depressurization during emergency situations to protect facilities, equipment, and personnel. One of the most critical characteristics of an FOV valve is its response time, which directly impacts its effectiveness and safety. In this article, we will explore the importance of response time in FOV valves, factors affecting it, and ways to improve and monitor it.

### Importance of rapid response time in FOV valves

- **Safety considerations:**  
A quick response time is essential for ensuring the safety of personnel working in the oil and gas industry. In an emergency situation, such as a sudden pressure increase, a rapid response from the FOV valve allows for the immediate release of excess pressure, minimizing the risk of explosions, fires, or other hazards.
- **Equipment Protection:**  
Rapid response time also protects equipment from potential damage caused by overpressure. By quickly opening and releasing pressure, the FOV valve prevents equipment failure and prolongs the service life of various components, reducing downtime and maintenance costs.
- **Environmental Impact:**  
A timely response from the FOV valve helps minimize the environmental impact of emergency situations. When the valve quickly opens and releases excess pressure, the potential for uncontrolled emissions and harmful environmental effects is significantly reduced.

### Improving Response time

- **Optimized Valve Design:**  
To improve the response time of FOV valves, engineers can optimize the valve design by using lightweight materials, reducing friction in moving parts, and minimizing pressure drops through the valve. Additionally, employing robust sealing mechanisms and designing the valve trim geometry for efficient fluid flow can also contribute to faster response times.
- **Selection of Appropriate Actuator:**  
Choosing the right actuator is critical for achieving quick response times in FOV valves. Spring-loaded, pneumatic, and high-speed hydraulic actuators are known for their rapid actuation

capabilities. Selecting an actuator that best suits the specific operating conditions and requirements of the application can help ensure optimal response times.

- **Control System Enhancements:** Improving the control system can also enhance the response time of FOV valves. Upgrading sensors, incorporating faster signal processing, and optimizing control algorithms can enable the control system to quickly detect emergency situations and send a signal to the actuator, resulting in a more rapid valve opening.
- **Regular Maintenance and Inspection:** Performing regular maintenance and inspection of the FOV valve, actuator, and control system is essential for maintaining optimal response times. Identifying and addressing potential issues, such as wear, corrosion, or component degradation, can help prevent a decline in performance and ensure a rapid response during emergencies.

In conclusion, the response time of Fast Opening Valves is a critical factor in ensuring the safety, equipment protection, and environmental responsibility of oil and gas facilities. By understanding and addressing the factors affecting response time, optimizing valve design, selecting appropriate actuators, enhancing control systems, and regularly maintaining and monitoring the valves, industry professionals can improve and maintain optimal response times for these critical components.

### 5.3. Factors affecting performance.

When discussing the performance of a flare valve, especially the FOV, several factors come into play that can either enhance or hinder its efficiency. In this section, we will explore the various elements that influence the performance of a flare valve and the potential consequences of these factors on the overall safety and operation of the oil and gas plant.

- **Valve Design and Material:** The design and material of the flare valve have a direct impact on its performance. In determining the ideal valve variety for a given situation be it a ball valve or an axial flow valve it's of paramount importance to make the right choice. Equally vital is the consideration of the construction material, which ought to exhibit remarkable resistance to corrosive forces and possess the ability to endure both extreme temperatures and immense pressure fluctuations. Inappropriate design or material choices can lead to premature wear, corrosion, and ultimately valve failure.
- **Installation and Alignment:** Proper installation and alignment of the valve within the flaring system are essential for optimal performance. Incorrect installation or misalignment can result in increased friction and wear on the valve components, negatively affecting response time and overall functionality.
- **Valve Sizing and Selection:** Choosing the correct valve size is vital for maintaining efficient pressure relief. An undersized valve may not provide adequate flow capacity, while an oversized valve can lead to excessive wear and reduced control. Proper valve sizing ensures that the valve can efficiently handle the plant's pressure relief requirements.
- **Maintenance and Inspection:** Regular maintenance and inspection of the flare valve are critical to maintaining peak performance. This includes checking for wear, corrosion, and other signs of degradation. Preventive maintenance and timely repairs can help extend the valve's service life and minimize the risk of failure.
- **Environmental Conditions:** The performance of a flare valve can be affected by the environmental conditions in which it operates. Extreme temperatures, humidity, and corrosive substances can all contribute to reduced valve efficiency and increased wear.

- **Operating Conditions:** Fluctuations in pressure and flow rates within the plant can impact the flare valve's ability to respond quickly and efficiently to overpressure events. Sudden changes in operating conditions may cause the valve to open or close unexpectedly, potentially leading to equipment damage or other safety hazards.
- **Control System Reliability:** The control system responsible for actuating the flare valve plays a significant role in its performance. A malfunctioning or unreliable control system can lead to delayed response times or even failure to open the valve when required.

In conclusion, several factors can influence the performance of a flare valve in a hydrocarbon processing plant. By understanding these factors and their potential impact on valve efficiency, operators can take proactive measures to optimize the flare valve's performance, ultimately ensuring the safety and reliability of the entire flaring system.

#### 5.4. Fail action: Fail Open

What does it mean when we talk about a flare valve's fail action being "Fail Open"? In the context of flare valve systems, the fail action refers to the default behavior of a valve in the event of a malfunction, loss of power, or other unexpected circumstances. Fail Open implies that, if any of these scenarios occur, the valve will automatically open to ensure the safe release of excess pressure and gases. But, why is it set up this way? Let's dive deeper into the importance of this functionality and its implications on plant safety.

Firstly, it's crucial to understand that a flare valve's primary role is to provide an emergency pressure relief mechanism for a hydrocarbon processing plant. In case of an overpressure event, the valve must open rapidly to release gases and prevent catastrophic consequences like explosions or equipment failure. This is where the Fail Open functionality comes into play. By defaulting to an open position, the valve ensures that pressure relief is always possible, even in the most unexpected situations.

So, what happens when the FOV doesn't meet its intended response time or fails to respond? The consequences can be severe, potentially leading to equipment damage, environmental pollution, and even loss of life. The Rupture Disk, another critical component in the flare valve system, is designed to provide a secondary pressure relief mechanism in case the FOV fails to open. However, relying solely on the Rupture Disk is not an ideal situation, as it is a single-use device that requires replacement after activation.

The importance of the Fail Open functionality cannot be overstated. Therefore, it's essential to understand common failure modes and their causes, as well as implement effective mitigation and prevention strategies. Regular inspection, maintenance, and monitoring of the valve's condition can go a long way in ensuring its proper functionality and safeguarding the plant against potential hazards.

In conclusion, the Fail Open functionality of flare valves plays a crucial role in ensuring the safe and efficient operation of hydrocarbon processing plants. By ensuring a rapid response to overpressure events, even under unexpected conditions, the Fail Open action of FOVs contributes to maintaining the integrity and safety of both personnel and equipment in the oil and gas industry.



# Chapter 6 Fail Action Functionality and Failure Modes

## 6.1. Reasons for increased response time

In the context of FOV within flaring systems, an increased response time can significantly impact the safety and efficiency of operations. It's therefore crucial to understand the various factors that might cause such an increase:

- **Mechanical Issues:**  
Mechanical problems are a common reason for increased response time. Wear and tear on the valve or its components, particularly the actuator, can impede the valve's ability to open swiftly. Corrosion, damage, or blockage in the valve mechanism can also affect the movement of the valve, slowing its response time.
- **Inadequate Maintenance:**  
Inadequate or improper maintenance can contribute to increased response time. Regular maintenance, including cleaning, lubrication, and component checks, is necessary to ensure that the valve operates optimally. Neglecting these tasks could lead to the accumulation of debris or corrosion that might interfere with the valve's operation.
- **System Pressure Variations:**  
Variations in system pressure can also affect the valve's response time. If the pressure upstream of the valve drops too low, it may reduce the actuation speed of the valve. Conversely, high back pressure downstream of the valve can make it harder to open, resulting in a slower response time.
- **Environmental Factors:**  
Environmental factors such as temperature extremes, humidity, or dust can impact the performance of the valve and its components. For example, extremely low temperatures could affect the viscosity of the hydraulic or pneumatic fluid in the valve actuator, slowing down its response.

## 6.2. Fail action mode: Importance and setup

As we saw the fail action mode of a FOV is a vital safety feature in the flaring systems of oil and gas plants. In general, the fail action mode of the FOV is set to 'Fail Open' to ensure the safe depressurization of the system in the event of a malfunction.

### 6.2.1 Importance of Fail Action Mode

As we have just seen in the previous chapter the importance of the fail action mode lies primarily in its role as a safeguard. In the event of a power loss, control signal failure, or other malfunctions, the FOV's fail action mode ensures that the valve opens to relieve excess pressure and prevent catastrophic damage to the plant. This Fail-Open setup can prevent over-pressurization that could lead to equipment failure, leaks, and potential safety hazards.



## **Setup of Fail Action Mode**

The setup of the fail action mode in an FOV typically involves configuring the valve actuator. In the Fail-Open configuration, the actuator is designed such that loss of power or control signal triggers the valve to open. This is usually achieved by incorporating a spring mechanism into the actuator design. When the actuator is powered, the spring is compressed. If power is lost, the spring expands, driving the valve to the open position.

Additionally, the fail action mode is often integrated into the plant's control and safety systems. Sensors and monitors keep track of the valve's status and the system's pressure levels, and the control system can command the valve to open if necessary.

### **6.3. Consequences of not meeting response time or failure to respond**

The performance of the FOV is essential to the safety and efficiency of flaring operations in the oil and gas industry. Any failure to meet the required response time or complete failure to respond can lead to severe consequences.

#### **Process Interruptions and Efficiency Loss**

A delayed response or non-response of the FOV can interrupt the plant operations. If the valve fails to open promptly during a pressure surge, it may necessitate the shutdown of certain processes until the issue is resolved. This could result in significant efficiency loss and production downtime.

#### **System Overpressure and Equipment Damage**

One of the primary roles of the FOV is to prevent overpressure in the plant by venting excess gases. If the FOV fails to respond in time or at all, it could lead to a buildup of pressure within the system. This overpressure can cause severe damage to the plant's equipment and infrastructure, leading to costly repairs and even longer operational downtimes.

#### **Safety Hazards**

Perhaps the most critical consequence of an FOV failing to meet its response time is the potential safety hazard. Overpressure conditions can lead to leaks or explosions, posing a significant risk to the safety of plant personnel and the surrounding environment.

#### **Environmental Impact**

Failure of the FOV to respond in time could also lead to unwanted environmental impacts. If excess gases are not vented properly and safely through the flare system, they could instead be released into the environment, contributing to air pollution and greenhouse gas emissions.

## 6.4. Common failure modes and their causes

To ensure the reliability and safety of FOV in flaring operations, it is crucial to understand common failure modes and their causes. This knowledge helps implement effective troubleshooting, prevention, and mitigation strategies. We will discuss these failure modes in two categories: mechanical failures and control system failures.

### 6.4.1 Mechanical Failures

- **Sticking or Jamming:**  
Sticking or jamming can occur due to debris accumulation, corrosion, or physical damage to the valve components. It can lead to the valve failing to open or close as required, affecting the response time and overall functionality.
- **Actuator Failure:**  
The actuator, responsible for moving the valve to its open or closed position, can fail due to electrical issues, pneumatic or hydraulic leaks, or mechanical damage. A faulty actuator can prevent the valve from responding to control signals, leading to a failure in operation.
- **Seal or Gasket Failure:**  
Seals and gaskets ensure the valve's tight closure, preventing leakage. Over time, these components can degrade due to wear and tear, exposure to harsh conditions, or inappropriate material selection. Failure of seals or gaskets can lead to leakage, impacting the efficiency of the flaring process.
- **Material Failure:**  
Material failure can occur due to inappropriate material selection or exposure to harsh operational conditions. This can result in the degradation of valve components, ultimately leading to valve failure.

### 6.4.2 Control System Failures

- **Loss of Control Signal:**  
Control system failures, such as loss of control signal, can prevent the FOV from responding as needed. This issue can lead to the valve failing to open or close, despite the changes in system pressure.
- **Sensor Malfunctions:**  
Sensor malfunctions can lead to inaccurate readings of system pressure or valve position, causing the control system to issue incorrect commands. As a result, the valve may not respond appropriately to pressure changes, potentially causing hazardous conditions.
- **Programming Errors:**  
Programming errors in the control system can also lead to improper valve operation. Incorrect logic or algorithms in the control software may result in incorrect valve commands, causing the valve to fail to respond as needed.

## 6.5. Mitigation and prevention strategies

To maintain the optimal functioning of flare valve systems and to ensure the safety and efficiency of operations in the oil and gas industry, various mitigation and prevention strategies can be employed. These strategies aim at reducing the chances of increased response time or complete failure to respond, which could lead to significant safety, environmental, and financial implications.

- Regular Maintenance and Inspection:**  
 A well-structured and regular maintenance and inspection program is crucial in ensuring the proper functioning of the FOV valve. Regular inspections allow for early detection of wear and tear or any malfunction that could affect the response time or cause a failure. Maintenance should include cleaning, lubricating, and replacing worn-out components.
- Material Selection:**  
 Selecting the appropriate materials for the construction of the flare valves and the accompanying systems is a key preventive measure. The materials used should be able to withstand the operational conditions such as high temperatures, corrosive environments, and high pressure.
- Proper Installation and Handling:**  
 Improper installation and handling of flare valve systems can lead to failures or increased response times. Proper installation should consider factors like valve orientation, connection to the control systems, and integration with the rupture disk. Furthermore, appropriate handling during operation and maintenance can prevent damage or premature wear and tear.
- Design Considerations:**  
 The design of the flare valve system should consider potential failure modes and operational challenges. For instance, the valve should be designed with a fail-open action mode to ensure depressurization even in case of failure. The design should also consider the expected response time, ease of maintenance, and integration with other systems.
- Electrical System Checks:**  
 Electrical failures can significantly affect the operation of the flare valve system, especially in relation to the control systems and actuators. Regular checks and maintenance of the electrical systems are necessary to prevent such failures. These checks should consider aspects like wiring integrity, insulation, grounding, and the performance of control systems and actuators.

In summary, mitigation and prevention strategies form a crucial part of the management of flare valve systems in the oil and gas industry. By ensuring regular maintenance and inspection, careful material selection, proper installation and handling, thoughtful design considerations, and electrical system checks, we can significantly reduce the risk of flare valve failure and ensure sustainable flaring practices.

## 6.6 practical example of the safety of a real flaring valve

The safety of a flaring valve is not merely theoretical, but grounded in empirical evidence. To illustrate, let's consider a real-life flaring valve, whose operation data over the last five years have been generously provided by MRC Global.

This valve, part of a crucial safety system, boasts several safety features designed to optimise efficiency and minimise risk. The core components of the valve, which can be seen in the following diagram, are meticulously engineered to ensure safe operations.

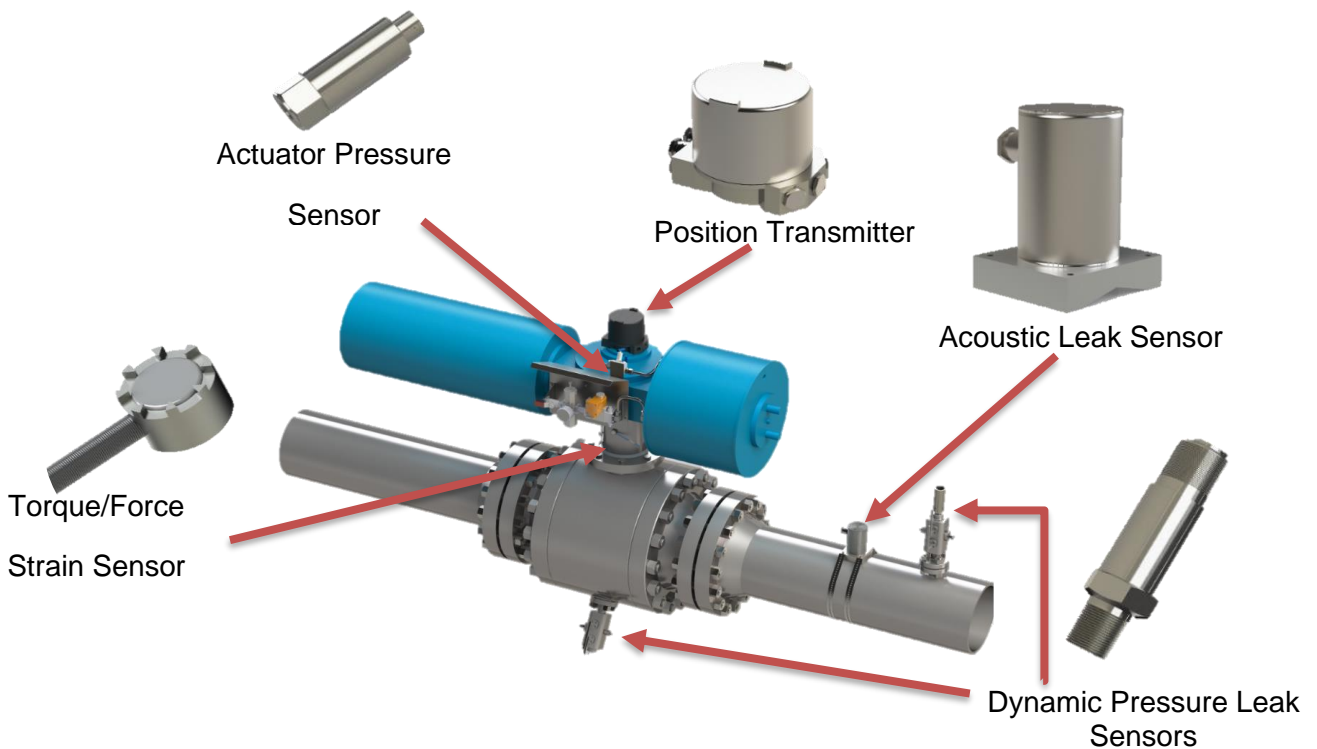

FIGURE 6-1 VALVE WATCH SENSORS

The data gathered from this valve allows us to generate a detailed analysis, one that not only scrutinises the safety components but also investigates any signs of efficiency loss over time. By graphically representing this data, we can visually ascertain the current operational safety of the valve.

### 6.6.1 brief summary of the sensors

- Torque Strain Sensor:** At the heart of a flaring valve's operation is the torque strain sensor. This sensor is a vital component that enables precise control over the torque applied in a rotating system, such as a valve or shaft. The torque strain sensor works based on the principles of strain gauge technology, where the sensor consists of a measuring body, generally of metal, and strain gauges mounted onto it. When external forces are applied, the sensor body deforms minutely. The strain gauges, connected to a Wheatstone bridge circuit, measure this deformation through changes in electrical resistance, and convert it into an electrical signal. This signal is then amplified and processed to provide a precise torque reading.
- Actuator Sensor:** Moving on to the actuator sensor, its role is to convert electrical signals into mechanical work, driving the operation of the valve mechanism. Actuators can be remotely operated and are critical safety components, stepping in to shut down operations in emergency situations that may be dangerous for human intervention. The actuator sensor often works in tandem with a position sensor to ensure accurate positioning of the valve.

- **Position Sensor:** The position sensor, as the name suggests, detects the position of the valve stem. It provides continuous feedback on whether the valve is in an "open", "closed", or intermediate position. This sensor plays a crucial role in maintaining operational reliability, ensuring that the mechanical valve's position matches the command signal at all times. In essence, the position sensor forms part of a closed-loop control system within the valve assembly, providing vital feedback to the actuator
- **Acoustic Leak Sensor:** The acoustic leak sensor is another critical component of the flaring valve system. Its function is to detect any leaks that may occur in the flaring valve's structure, primarily by monitoring the acoustic signals produced by the valve. The acoustic leak sensor works on the principle of acoustic signal analysis - it detects unusual or irregular sound patterns that could indicate a leak in the valve. This type of sensor is crucial for maintaining the safety and efficiency of the valve operation.
- **Dynamic Pressure Leak Sensor:** Last but not least is the dynamic pressure leak sensor. This sensor is designed to monitor the pressure inside the valve continuously. It does this by measuring the dynamic pressure changes within the valve system. When a leak occurs, it leads to a drop in pressure which is detected by the sensor. This type of sensor plays a vital role in leak detection and the overall safety of the flaring valve operation.

In Conclusion, Sensors in flaring valves are indispensable tools in the process industry, providing critical data for the safe and efficient operation of these valves. From torque strain sensors that measure and control the application of force, to actuator and position sensors that ensure accurate valve positioning, to acoustic and dynamic pressure leak sensors that detect potential leaks, each sensor plays a critical role. Understanding how these sensors work and their importance can help in the effective design, operation, and maintenance of flaring valves in various industrial settings.

### 6.6.2 interpret the information

Analyzing the collected data, we find records of 410 operational instances of the valve over the past five years. Visualizing this data, we can generate a comprehensive graph detailing the various parameters recorded by the sensors during these operations:

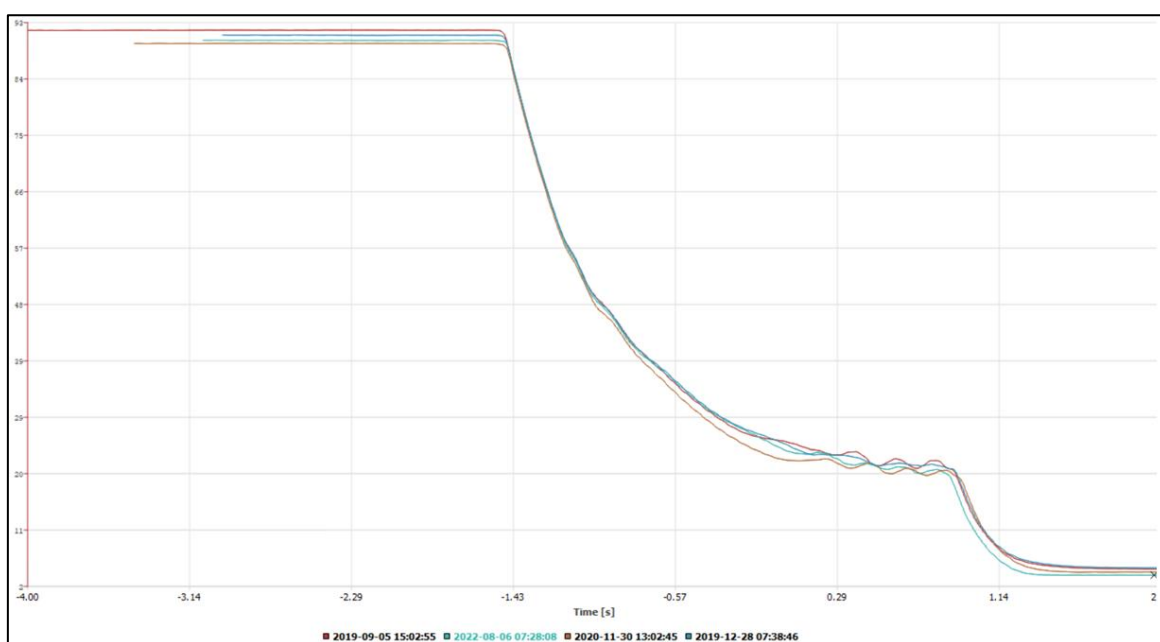

FIGURE 6-2 OVERALL RESULTS FROM 5 YEARS OF OPERATION

The x-axis of the graph represents the valve's opening time in seconds. It can be observed that the opening speed has remained consistent across all 410 instances. The resulting curves, almost indistinguishable, demonstrate an extreme similarity in performance, indicating consistent performance over time.

Critically, the opening time remains below two seconds for each instance. As discussed in previous chapters, a response time less than two seconds is crucial for a FOV valve in a flaring system. The consistency in achieving this standard suggests a high operational efficacy and a low risk of failure.

In conclusion, these data strongly suggest that the studied valve is functioning correctly and poses a minimal risk of failure, a testament to its robust design and the reliable performance of its safety features.

# Chapter 7 FOV as a Safety Instrumented Function (SIF)

## 7.1. Definition and implications of SIF

A SIF is a crucial component in the context of process safety in the oil and gas industry. It is designed to ensure that a specific process operates within predefined safety parameters, and when a potentially hazardous situation arises, it takes appropriate actions to bring the system to a safe state. In this section, we will discuss the definition of SIF and its implications in the context of flare valve systems.

A SIF is a set of interconnected components that work together to accomplish a specific safety-related task within a Safety Instrumented System (SIS). These components include sensors, logic solvers, and final control elements, such as valves. The primary objective of a SIF is to detect abnormal process conditions and take corrective actions to maintain the system's integrity and prevent hazardous events.

### 7.1.1 Implications of SIF in Flare Valve Systems

The FOV is an essential component of a flare valve system, as it ensures rapid depressurization of the plant in case of an emergency. Given its critical role in maintaining process safety, the FOV can be considered a SIF within the flare valve system. The implications of classifying FOV as a SIF include:

- **Safety Integrity Level (SIL) Requirements:** The FOV must meet specific performance requirements concerning its reliability and the probability of failure on demand (PFD). These requirements are defined by the Safety Integrity Level (SIL) classification, which ranges from SIL 1 (lowest) to SIL 4 (highest).
- **Systematic Capability:** The FOV, along with other components of the SIF, must demonstrate a systematic capability that ensures the SIF's overall performance. This involves robust design, proper installation, and regular maintenance and testing to verify that the SIF is functioning as intended.
- **Functional Safety Management:** The management of the FOV as a SIF requires a comprehensive functional safety management system. This includes clear policies and procedures for the design, operation, and maintenance of the flare valve system, as well as regular audits and assessments to ensure compliance with industry standards and best practices.
- **Risk Reduction Measures:** The FOV as a SIF must provide adequate risk reduction, which is measured by comparing the residual risk after the SIF is implemented to the tolerable risk levels established for the process. The effectiveness of the FOV in reducing risk can be quantified using techniques such as Layer of Protection Analysis (LOPA).

By understanding the definition and implications of a Safety Instrumented Function, we can better appreciate the critical role of the FOV in maintaining process safety in the oil and gas industry. In the following sections, we will delve deeper into the management of FOV as a SIF, including diagnostics, condition monitoring, and compliance with industry standards.

## 7.2. Managing SIF during operations: Diagnostics and condition monitoring

The management of SIFs during operations pivots upon two crucial elements: Diagnostics and Condition Monitoring.

### 7.2.1 Diagnostics

Diagnostics play an integral role in determining the operational health of a FOV. In essence, diagnostics involve systematic checks carried out to detect potential abnormalities, deviations, or failures in the valve system.

The FOV, being a critical element in a flaring system, is frequently equipped with a self-diagnostic feature. This feature monitors key performance indicators such as the response time of the valve and the status of the Fail Open function. If there's an increase in the valve's response time or the Fail Open function appears compromised, the diagnostic system alerts the operators, thereby enabling swift preventive or corrective action.

However, diagnostics are not a one-time procedure. Regular diagnostic checks are of utmost importance to maintain the FOV's functionality, and the frequency of these checks is typically defined based on factors like the valve's age, operational conditions, and historical performance data.

### 7.2.2 Condition Monitoring

While diagnostics deal with the detection of potential issues, condition monitoring is focused on the ongoing assessment of the valve's operational state. It's a proactive approach aiming to predict potential failures before they occur, thereby minimizing risks and enhancing safety.

Condition monitoring of an FOV, particularly in its role as an SIF, involves tracking parameters such as pressure fluctuations, seal integrity, and signs of wear and tear. Advanced techniques like vibration analysis and thermographic inspection may also be employed to identify anomalies that might not be evident in routine visual inspections or functional checks.

Moreover, condition monitoring provides valuable data that can be used to optimize maintenance schedules, thereby improving the overall reliability and lifespan of the FOV.

## 7.3. Performance metrics and indicators

Performance metrics and indicators are paramount in evaluating the effectiveness of the FOV as a SIF. These measures allow for comprehensive understanding and ongoing monitoring of the FOV's operational performance.

### Performance Indicators

Key Performance Indicators (KPIs) are quantitative measures used to assess the efficiency of the FOV in fulfilling its SIF role. Some of the most significant KPIs for an FOV include:

- **Response Time:** This KPI measures how quickly the FOV can open in response to an operational demand. The standard response time of 2 seconds is crucial to maintain for effective depressurization.
- **Fail Open Rate:** This measures the consistency of the FOV in fulfilling its Fail Open functionality. A high Fail Open rate indicates a robust and reliable FOV.



- **Maintenance Frequency:** This indicates how often maintenance is required to keep the FOV in optimal condition. A lower maintenance frequency generally suggests a more reliable and efficient FOV.

## Performance Metrics

Performance metrics, while similar to KPIs, are more focused on the qualitative aspects of the FOV's operation. These include:

- **Reliability:** This metric considers the overall dependability of the FOV in maintaining its functions under various operational conditions. High reliability signifies fewer unexpected failures and less downtime.
- **Safety Integrity Level (SIL):** This assesses the FOV's ability to perform its safety functions under stipulated conditions. A higher SIL indicates a lower probability of failure on demand.
- **Operational Efficiency:** This refers to the FOV's ability to perform its functions with minimal resource wastage. High operational efficiency typically leads to cost savings and reduced environmental impact.

In summary, performance metrics and indicators provide a comprehensive assessment of the FOV's effectiveness as an SIF. They play a critical role in the ongoing management and optimization of the flare valve system, ensuring the sustainment of safe and efficient flaring practices in the oil and gas industry.

## 7.4. Safety integrity level (SIL) classification

The Safety Integrity Level (SIL) classification is a significant concept in the context of safety instrumented systems, including flare valves, within the oil and gas industry. The SIL classification measures the relative level of risk reduction provided by a safety function or a SIF, such as a flare valve, and helps specify a target level of risk reduction. Essentially, SIL serves as a performance metric for a safety instrumented function

### Understanding SIL: Definition and Determination

SIL is defined in the International Electrotechnical Commission's (IEC) standard IEC 61508. Four SILs are defined in this standard, with SIL 4 being the most dependable and SIL 1 the least. The applicable SIL for a safety function is determined based on a combination of quantitative and qualitative factors such as the development process and safety life cycle management. To achieve a given SIL, a device or system must meet the requirements for both hardware safety integrity and systematic safety integrity.

The assignment of SIL is an exercise in risk analysis. The risk associated with a specific hazard, intended to be protected against by a SIF, is calculated without considering the risk reduction effect of the SIF. This unmitigated risk is then compared against a tolerable risk target. If the unmitigated risk is higher than the tolerable risk, it must be addressed through risk reduction of the SIF, correlating with the SIL target.

<b>Frequency</b>	5	SIL3	SIL4	X	X	X
	4	SIL2	SIL3	SIL4	X	X
	3	SIL1	SIL2	SIL3	SIL4	X
	2	-	SIL1	SIL2	SIL3	SIL4
	1	-	-	SIL1	SIL2	SIL3
		1	2	3	4	5
<b>Severity of Consequence</b>						

FIGURE 7- 1 SIL LEVEL CHART

### Assigning a SIL

SIL is determined through risk analysis, comparing unmitigated risk against a tolerable risk target. If unmitigated risk exceeds tolerable risk, it must be reduced, and the required risk reduction is correlated with the SIL target. Risk matrices, risk graphs, and Layers of Protection Analysis (LOPA) are common methods used to assign a SIL. In LOPA, available safety measures are listed, each assigned a hazard risk reduction factor, and an effective hazard frequency is calculated with these layers applied. This process is reevaluated with any changes in process design, operating conditions, or equipment.

## 7.5. Compliance with industry standards

The assurance of safety and efficiency in the oil and gas industry is largely driven by adherence to established industry standards. In the context of the FOV functioning as a SIF, compliance with such standards is essential.

Several industry standards govern the design, operation, and maintenance of an FOV as an SIF. The International Electrotechnical Commission (IEC) 61511 standard, for instance, specifically addresses the safety requirements for the operation of SIFs in process industries. It outlines best practices for the entire lifecycle of an SIF, from design and installation to operation, maintenance, and eventual decommissioning.

Another critical standard is the American Petroleum Institute (API) Standard 521, which provides guidelines for pressure-relieving and depressuring systems, including the role of the FOV in such systems.

Ensuring compliance with these standards involves a multifaceted approach. Rigorous testing and regular audits are integral parts of this process. Testing ensures that the FOV functions as expected under various operational conditions, while audits verify adherence to stipulated procedures and regulations.

Furthermore, training personnel in these standards is crucial to ensure they understand their roles in maintaining compliance. This not only enhances operational safety but also fosters a culture of safety within the organization.

Compliance with industry standards offers several benefits. Firstly, it ensures a high level of safety, thereby minimizing risks to personnel and equipment. Secondly, it enhances operational efficiency and reliability, contributing to more sustainable flaring practices. Lastly, it can also provide a competitive edge in the industry, as compliance is often seen as a mark of quality and reliability.

# Chapter 8 Advanced Diagnostics and Predictive Maintenance

The industry has increasingly focused on leveraging advanced technologies for diagnostics and predictive maintenance. This chapter delves into the potential of these technologies in managing and optimizing flare valve systems, ensuring their efficient and safe operation.

## 8.1. Predictive Maintenance Overview

Predictive maintenance represents a proactive approach that focuses on predicting equipment failure to schedule maintenance, thereby preventing unexpected equipment breakdowns. It involves monitoring equipment performance and condition during routine operations, using various data analysis tools and techniques to predict maintenance requirements.

Unlike traditional reactive maintenance (fix it when it breaks) or preventive maintenance (fix it before it breaks), predictive maintenance is grounded in the principle of "fix it just as it is about to break." It leverages the power of data, machine learning algorithms, and advanced analytics to anticipate potential issues, thereby reducing downtime, saving costs, and improving overall operational efficiency.

## 8.2. Role of Advanced Diagnostics in Predictive Maintenance

Advanced diagnostics are fundamental to the implementation of predictive maintenance. They allow for continuous or periodic monitoring of equipment parameters, providing invaluable data that can indicate potential issues long before they result in system failure.

In the context of flare valve systems, advanced diagnostics can monitor various parameters such as pressure, temperature, flow rates, and valve response times. By analyzing this data, potential problems can be identified, and maintenance can be scheduled before a catastrophic failure occurs. For instance, an increase in the valve's response time could be indicative of impending mechanical failure, allowing for timely intervention.

## 8.3. Benefits of Predictive Maintenance for Flare Valve Systems

Predictive maintenance offers numerous benefits, particularly for critical systems like flare valves.

**Reduced Downtime:** By predicting failures before they occur, predictive maintenance allows for planned intervention, reducing unexpected downtime and increasing system availability.

**Cost Savings:** While the upfront cost of implementing predictive maintenance can be substantial, the long-term savings resulting from reduced downtime and preventive repairs can offset the initial investment.

**Enhanced Safety:** For flare valve systems, a failure can pose significant safety risks. Predictive maintenance enhances the safety of operations by mitigating the risk of unexpected equipment failure.

Increased Equipment Lifespan: By identifying and addressing maintenance issues early, predictive maintenance can prolong the equipment's operational lifespan.

### 8.4.Real Case Studies of Predictive Maintenance in the Oil and Gas Industry

In predictive maintenance, the use of sensor technology to monitor the health of equipment in real time is a critical component. The data provided by these sensors can reveal early warning signs of potential failure, enabling intervention before a catastrophic event occurs. I have received a set of illustrative graphs from MRC Global. These graphs demonstrate the outputs from sensors incorporated into a real flaring valve, shedding light on the practical application of predictive maintenance in the oil and gas industry.

In these graphs, three different curves are represented: "actuator pressure" in blue, "stem torque" in red, and "valve travel" in purple. Let's delve into the meaning of each of these functions:

- **Actuator Pressure (Blue curve):** This represents the hydraulic or pneumatic pressure exerted by the actuator to open or close the valve. Any irregularities in this function could indicate problems with the actuator, such as a weak spring, galling, corrosion, or excessive friction in the scotch yoke mechanism. In the provided case, a prolonged sequence of pressure bleed-off before equilibrium points to potential issues with the valve assembly.
- **Stem Torque (Red curve):** This is the twisting force applied to the valve stem, which is required to move the valve disc. An increase in the stem torque might indicate a growing resistance in the valve movement, potentially due to factors such as wear and tear, incorrect valve sizing, or inadequate maintenance.
- **Valve Travel (Purple curve):** This function indicates the position of the valve, i.e., how open or closed it is. In the context of predictive maintenance, observing any deviations from expected valve travel can be a vital indicator of valve health.

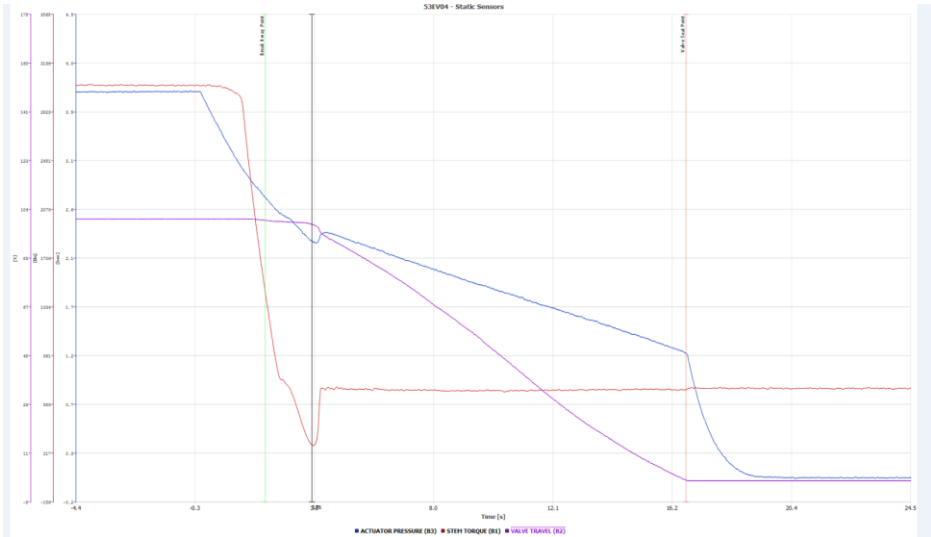

FIGURE 8 -1 OPENING TEST

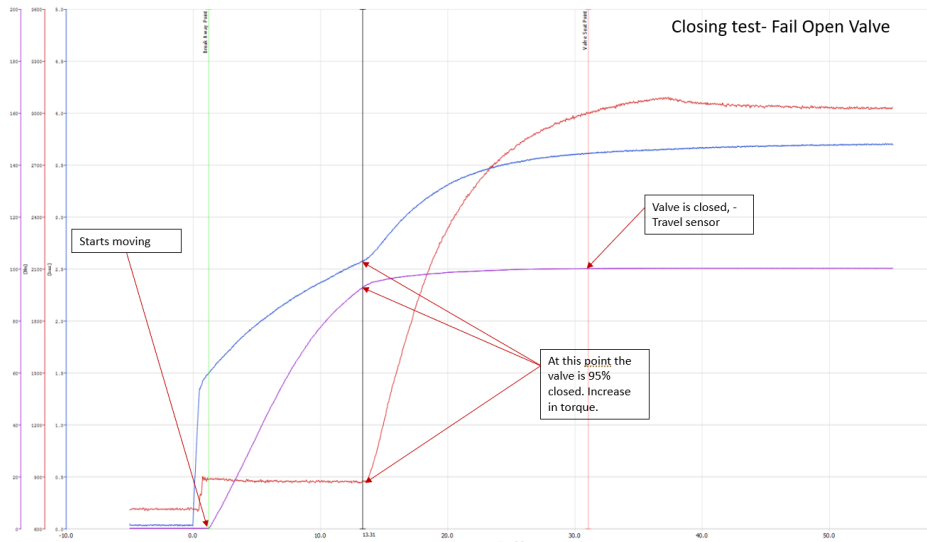

FIGURE 8-2 CLOSING TEST- FAIL OPEN VALVE

The data provided is based on two tests: the opening test and the closing test for a fail-open valve. These tests monitor valve behavior during both opening and closing processes, providing a holistic view of the valve's operational health.

The graphs highlight three zones of importance: "Starts moving", "At this point the valve is 95% closed. Increase in torque.", and "Valve is closed, - Travel sensor". These zones represent critical stages in the valve's operational cycle:

**Starts Moving:** This is the initial stage where the valve begins to open or close in response to the actuator pressure. Monitoring this stage can help identify any delays or difficulties in initiating valve movement.

**At this point the valve is 95% closed. Increase in torque:** This stage represents the final phases of valve closure, where an increase in torque is required to fully close the valve. A spike in torque at this point might suggest potential issues, like an obstruction or increased friction.

**Valve is closed, - Travel sensor:** This is the point at which the valve is fully closed, confirmed by the travel sensor. Any discrepancies between the expected and actual valve position at this stage could indicate a malfunction.

By continuously monitoring these parameters and analyzing them over time, potential issues can be identified early, making these graphs an excellent tool for predictive maintenance. The real-time data provided by these sensors enables proactive maintenance decisions, minimizing the risk of unexpected equipment failure and ensuring the efficient and safe operation of flaring valve systems.

### conclusions of the graphs

The opening test presents compelling evidence of the importance of sensor data in predictive maintenance, particularly in the oil and gas industry. The real-world test data provided by MRC Global offers practical insight into the potential issues that can be identified and mitigated through continuous monitoring and analysis of key valve parameters.

From the Pressure sensor data, we observe a significant deviation from expected behavior. Specifically, there is an extended sequence of pressure bleed-off before equilibrium is achieved between the spring and pressure forces. Approximately 30% of the pressure is discharged before the valve initiates movement, hinting at potential problems within the actuator, such as a deficient spring, galling,

corrosion, or excessive friction in the scotch yoke mechanism. Alternatively, this issue could also be related to the valve itself.

The Strain sensor data further clarifies the situation. An increase in the breakaway force, which aligns with the observations from the pressure and travel sensors, may be an early warning sign of issues affecting the efficient operation of the valve.

In summary, the provided case study underscores the value of predictive maintenance in the oil and gas industry. Through careful analysis of sensor data, potential problems can be proactively identified and addressed, significantly reducing the risk of costly equipment failures and shutdowns. The integration of such predictive maintenance practices, supported by sensor technology, can contribute to safer, more efficient, and more sustainable operations within the industry.

## **8.5. The Future of Predictive Maintenance**

With the rapid advancement in technologies like IoT, AI, and machine learning, the future of predictive maintenance looks promising. The increasing availability of high-quality sensor data, coupled with sophisticated analytics, is set to further enhance the accuracy of predictions.

Furthermore, as the industry moves towards more digitalized operations, the integration of predictive maintenance into broader asset management strategies is anticipated. This holistic approach will allow companies to optimize their maintenance activities fully, resulting in improved reliability, efficiency, and safety.

# Chapter 9 Sustainable Flaring Practices and Technological Advancements

## 9.1. Emission reduction techniques

Flaring involves the burning of unwanted or excess gases. While it serves crucial safety and operational functions, it also contributes to air pollution and climate change due to the release of carbon dioxide and methane. As such, the reduction of emissions from flaring is an urgent priority, not just for the industry, but also for the global community.

A variety of techniques and strategies have been devised to address this issue. One fundamental step is to **keep an accurate inventory of flaring activity**. By tracking the quantity and type of gases flared, as well as the time and location of flaring events, companies can better understand the scale and nature of their emissions. This information can help identify opportunities for emission reduction, enable the evaluation of emission reduction efforts, and facilitate compliance with emission reporting requirements.

Another strategy is to **prevent flaring by designing systems that do not produce waste gases**. This might involve modifying operational processes to reduce the production of excess gases, redesigning equipment to capture and reuse these gases, or both. Such preventative measures require upfront investment but can yield significant long-term benefits by reducing the need for flaring and thus, its associated emissions.

Moreover, it's becoming increasingly common to **recover waste gases as products to be sold**. Instead of being viewed as waste, excess gases can be seen as resources that have potential economic value. They can be captured, processed, and sold for various uses, such as heating fuel or raw material for chemical production. This not only reduces emissions but also helps improve operational efficiency and profitability.

Furthermore, **injecting waste gases into oil or gas reservoirs** has been adopted as a viable solution. This method not only eliminates the need for flaring but also enhances oil or gas recovery. By injecting gases back into the reservoirs, pressure can be maintained, improving the efficiency of extraction.

Finally, there's growing interest in **finding alternative uses for flared gases**. One example is using these gases to generate electricity, either on-site or through the grid. This can be particularly advantageous in remote areas where energy sources are limited. Additionally, it can provide a cleaner alternative to diesel generators, which are commonly used in the industry but have a higher environmental impact.

## 9.2. Improvements in flare valve design

Alongside the development of emission reduction techniques, significant advancements have been made in the design of flare valves, the components responsible for regulating the release of gases in a flare system.

The external air ring design is a notable development in this regard. Traditionally, air-assisted flares have utilized complex and costly designs to inject air into the flare stream, enhancing combustion efficiency. The external air ring design simplifies this process by using a ring of small pipe located around a central pipe or utility flare. Not only is this design more cost-effective than others, but it's also especially suited for handling large volumes of low-pressure waste. This means it can be effectively



deployed in scenarios where large amounts of waste gases are generated, helping to reduce emissions without incurring prohibitive costs.

Another significant advancement is the redesign of the Fluid Catalytic Cracking Unit (FCCU) flare system. Specifically, a new flame arrester valve group was designed to improve system performance and safety. This design, coupled with the adoption of Low Level Ignition and Stepped Firing measures, helped lower the installation height of the igniter, reducing operational risks. The improved design demonstrates how innovation in flare valve design can enhance safety while also contributing to emission reduction.

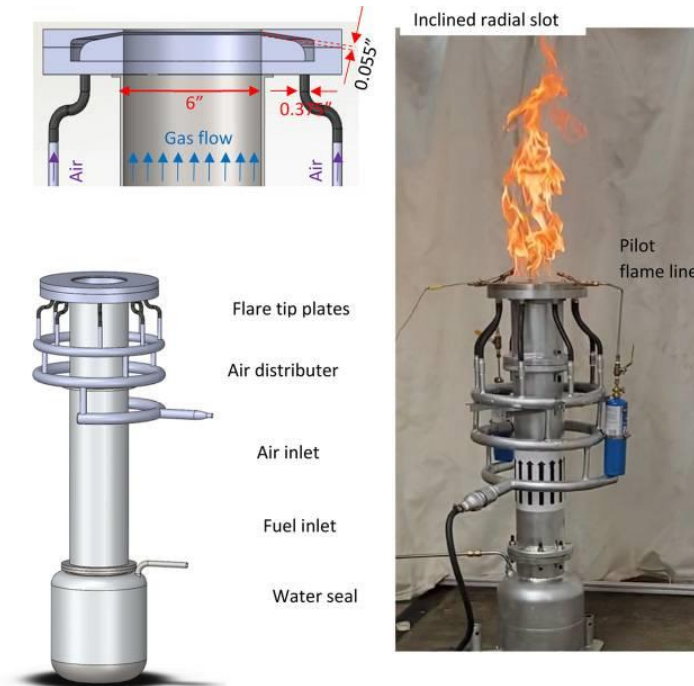

FIGURE 9 -1 FLARING WITH EXTERNAL AIR RING

### 9.3. Alternative technologies and solutions

Given the environmental implications of flaring, there is a growing interest in developing and implementing alternative technologies and solutions that can mitigate its impact. The goal is to explore ways to efficiently utilize the waste gases instead of burning them off, thereby reducing emissions and potentially creating economic value.

One such innovative solution is the "virtual gathering system" developed by Edge, a company based in Malvern, Pennsylvania. This system captures the entire gas stream and converts it to Liquefied Natural Gas (LNG). By doing so, it not only prevents the release of gases into the atmosphere but also transforms them into a form that can be easily transported and sold for various uses. This technology represents a paradigm shift in the way the industry perceives and handles waste gases. Instead of being seen as a problem to be managed, these gases are treated as a resource to be harnessed, aligning economic incentives with environmental goals.

Another promising technology is the Ener-Core Power Oxidizer, which offers a revolutionary approach to handling waste gases. While details about its specific functionality are not available, it's clear that this technology has the potential to significantly expand the industry's arsenal of tools for managing waste gases and reducing emissions. Its development underscores the crucial role of technological innovation in addressing environmental challenges.

Furthermore, a wide array of alternative uses for flared gases have been proposed. These include using the gases for secondary oil recovery, as feedstock for petrochemical plants, and for domestic uses such

as heating. These gases can also be converted into LNG and Compressed Natural Gas (CNG), both of which can be used as cleaner-burning alternatives to other fossil fuels. An intriguing proposal is the possibility of storing these gases as hydrate for future use or other purposes, given that gas hydrate is stable above the freezing point of water and under sufficiently high pressure. This approach not only provides a solution for managing excess gases but also offers a potential energy storage option, which could be particularly valuable in light of the increasing demand for energy storage solutions due to the growth of intermittent renewable energy sources.

#### **9.4. Regulatory and industry standards**

Regulations and industry standards play a crucial role in shaping the practices and behaviors of the oil and gas industry. Governments, regulatory bodies, and industry groups worldwide have established a variety of rules and guidelines to govern flaring practices, aiming to minimize their environmental impact and ensure the safety and health of workers and communities.

Governments of oil-producing countries have a vital role in ending routine gas flaring and venting, which predominantly involves methane, a potent greenhouse gas. Through effective regulation and policies, these governments can create an operating environment that supports and incentivizes reduction of gas flaring and venting. This might involve setting stringent emission standards, providing financial incentives for emission reduction efforts, or both.

In the United States, the Environmental Protection Agency (EPA) has set regulatory heating value limits for flares: 300 Btu/scf for assisted flares and 200 Btu/scf for unassisted flares. These limits must be met at all times, requiring companies to continuously monitor and manage the heating value of their vent gas over the full range of operating scenarios. This regulation helps ensure that flares operate efficiently and reduce their emissions as much as possible.

One of the most ambitious and influential initiatives is the Zero Routine Flaring by 2030 (ZRF). Launched in 2015, the ZRF Initiative commits governments, oil companies, and other stakeholders to end routine flaring no later than 2030. This initiative fosters cooperation among all relevant stakeholders, encouraging the development and application of advanced technologies, the implementation of effective regulations, and the provision of necessary financial support.

Regulations are also being updated at the national level to tighten controls over flare operations. For instance, in 2015, the EPA in the United States published a new rule under 40CFR Parts 60 and 63 titled "Petroleum Refinery Sector Risk and Technology Review and New Source Performance Standards." This rule established several new requirements for the operation of flares at petroleum refineries, reflecting the ongoing evolution of regulatory standards in response to emerging scientific knowledge and technological advancements.

Regulators and financial institutions are also urged to design and include climate standards as part of asset sales to avoid transferring assets to poor environmental performers. This strategy would help ensure continued high environmental performance with lower flaring and venting rates despite assets changing hands. This is an interesting approach that recognizes the role of market transactions in influencing environmental performance, underscoring the need for a holistic approach that integrates environmental considerations into all aspects of business operations.

On a more detailed level, the Code of Federal Regulations (CFR) in the U.S. has specific requirements for flare control devices. As per 40 CFR § 63.670, the owner or operator of a flare used as a control device for an emission point must meet the applicable requirements for flares as specified in the sections of the code. This regulation ensures that all flare operations comply with the necessary technical standards, contributing to the overall goal of emission reduction.

## 9.5 real study of the reduction of emissions in a flaring valve

In this chapter, a real-life case study is presented, highlighting the tangible and significant impacts of sustainable flaring practices in the oil and gas industry. By analyzing data provided by the company MRC Global, we can examine the changes in the frequency of flare valve operations over a five-year period, and the resulting implications for emissions and pollution.

### Understanding the Emission Trends

In the initial year, the flare valve in question was operated a staggering 259 times. In the subsequent years, the number decreased significantly: 105 times in the second year, 29 times in the third, 11 in the fourth, and 6 in the final year. This continuous and significant reduction in the operation of the flare valve represents an important leap towards sustainable flaring practices.

Fewer flare valve activations signify a decrease in flaring events, hence less combustion of excess gases. This directly translates to a substantial reduction in pollutant emissions, including carbon dioxide (CO<sub>2</sub>), methane (CH<sub>4</sub>), and other volatile organic compounds. Thus, it is evident that fewer activations of the flare valve invariably leads to a decrease in environmental contamination.

### Factors Influencing Reduced Valve Operation

However, understanding the underlying reasons for this decreasing trend in valve operations is equally important. Several factors contribute to this desirable outcome: the implementation of more efficient operational protocols, advancements in valve technologies, and adherence to strict regulatory guidelines.

Efficient operational practices, such as better inventory management and predictive maintenance, can decrease the frequency of pressure spikes, reducing the need for flaring. Additionally, the technological advancements in valve design, focusing on efficient sealing and optimal pressure regulation, have further reduced the necessity of frequent valve activations.

Regulations and guidelines also play a critical role in promoting sustainable practices. Strict emission standards and penalties have incentivized industries to minimize flaring events. In response, industries have adopted better equipment, technology, and practices to adhere to these standards.

In conclusion, fewer operations of the flare valve have a direct and substantial impact on emission reduction. However, achieving this requires a concerted effort across different facets, including operational management, technological advancements, and regulatory adherence.

#### Data Collected:

-Year No. 1: 259 Stokes

-Year No. 2: 105 Stokes

-Year No. 3: 29 Stokes

-Year No. 4: 11 Stokes

-Year No. 5: 6 Stokes (August)

The valve is still in full operation based on the Condition & Performance Monitoring data collected by the online monitoring system, ValveWatch.



## 10. Conclusions

This bachelor thesis embarked on an in-depth journey into the world of flare valves, aiming to shed light on this critical yet often overlooked component of the flaring process within the oil and gas industry. Throughout this research, it has become abundantly clear that flare valves, with their unique "fail-open" function, play a pivotal role in safeguarding industry infrastructure and personnel against potential disasters arising from unexpected pressure surges.

Our exploration spanned across the design, operation, and integration of flare valves within the flaring system. We examined the core components of these valves, such as ball valves, axial flow valves, and rupture disks, thereby gaining a deeper understanding of the underlying mechanisms that enable them to perform their crucial functions. In particular, the immense force exerted during the fail-open action of the valves, often exceeding 100 tons, has been emphasized as a critical safety measure within the industry.

This research also delved into the intricate aspects of SIFs as they relate to flare valves. We investigated the management of these functions during operations, their potential failure implications. This analysis has illuminated the important influence these factors have on the performance, maintenance requirements, and overall effectiveness of flare valve systems.

Undoubtedly, the insights generated by this research make a substantial contribution to the broader discourse on safety and sustainability within the oil and gas industry. By bringing the intricacies of flare valves to the forefront, we have underscored the need for comprehensive understanding and meticulous management of these safety-critical components.

In conclusion, this thesis has revealed the vital role flare valves play in maintaining safe and sustainable operations within the oil and gas industry. It emphasizes that the careful study of these valves, and their effective integration within the broader flaring system, is not just a technical necessity but a requisite for industry progress. Future research should aim to build upon this foundation, continuing to explore and innovate for safer, more efficient, and sustainable industry practices.



## 11. References

- [https://instrumentationtools.com/valve-functions-and-basic-parts/#google\\_vignette](https://instrumentationtools.com/valve-functions-and-basic-parts/#google_vignette)
- <https://engineeringlibrary.org/reference/valves-doe-handbook>
- <https://control.com/textbook/control-valves/valve-packing/>
- <https://chemicalengineeringworld.com/different-types-of-valves/>
- <https://www.unifiedalloys.com/blog/valves-101>
- <https://blog.thepipingmart.com/other/types-of-valves-used-in-piping-a-complete-guide/>
- <https://chemicalengineeringworld.com/gas-flare-system-working/>
- <https://www.iea.org/reports/flaring-emissions>
- <https://www.hydrocarbonprocessing.com/magazine/2021/april-2021/process-engineering/design-considerations-when-flaring-ethylene-oxide>
- <https://oaktrust.library.tamu.edu/bitstream/handle/1969.1/173412/TANEJA-THESIS-2018.pdf>
- <https://instrumentationtools.com/difference-between-quick-opening-linear-equal-percentage-control-valve-characteristics/>
- <https://instrumentationtools.com/valve-characteristics/>
- <https://www.spiraxsarco.com/learn-about-steam/control-hardware-electric-pneumatic-actuation/control-valve-characteristics>
- <https://blog.swansonflo.com/2017/11/understanding-linear-equal-percentage.html>
- <https://caltsensor.com/what-is-torque-sensor-how-does-it-work/>
- [https://www.hbkworld.com/en/knowledge/resource-center/articles/2023/how-does-a-torque-transducer-actually-work#!ref\\_www.hbm.com](https://www.hbkworld.com/en/knowledge/resource-center/articles/2023/how-does-a-torque-transducer-actually-work#!ref_www.hbm.com)
- <https://sensitivus.com/faq/how-torque-sensors-work/>
- [https://www.hbkworld.com/en/knowledge/resource-center/articles/2023/shaft-torque-transducers-basic-faq#!ref\\_www.hbm.com](https://www.hbkworld.com/en/knowledge/resource-center/articles/2023/shaft-torque-transducers-basic-faq#!ref_www.hbm.com)
- <https://www.slb.com/resource-library/article/valve-insights/how-it-works-actuators>
- <https://www.spiraxsarco.com/learn-about-steam/control-hardware-electric-pneumatic-actuation/control-valve-actuators-and-positioners>
- <https://www.ifm.com/us/en/us/overview/valve/technology-overview/tech-overview>
- <https://methaneguidingprinciples.org/resources-and-guides/best-practice-guides/flaring/>
- <https://www.ncbi.nlm.nih.gov/pmc/articles/PMC9713881/>

- [https://www.researchgate.net/publication/294246847\\_improvements\\_of\\_flare\\_system\\_in\\_FCCU](https://www.researchgate.net/publication/294246847_improvements_of_flare_system_in_FCCU)

-<https://www.worldbank.org/en/topic/extractiveindustries/publication/global-flaring-and-venting-regulations>

- <https://ehsdailyadvisor.blr.com/2022/08/epa-considers-revising-flare-pollution-regulation/>

[https://www.ncbi.nlm.nih.gov/core/lw/2.0/html/tileshop\\_pmc/tileshop\\_pmc\\_inline.html?title=Click%20on%20image%20to%20zoom&p=PMC3&id=9713881\\_ao2c04618\\_0002.jpg](https://www.ncbi.nlm.nih.gov/core/lw/2.0/html/tileshop_pmc/tileshop_pmc_inline.html?title=Click%20on%20image%20to%20zoom&p=PMC3&id=9713881_ao2c04618_0002.jpg)

- <https://www.icheme.org/media/8914/xxiv-paper-18.pdf>

- <https://flareintel.com/insights/minimising-flaring-near-existing-demand-centres>

-<https://www.dnv.com/article/terminology-explained-what-is-safety-integrity-level-sil--207747>