

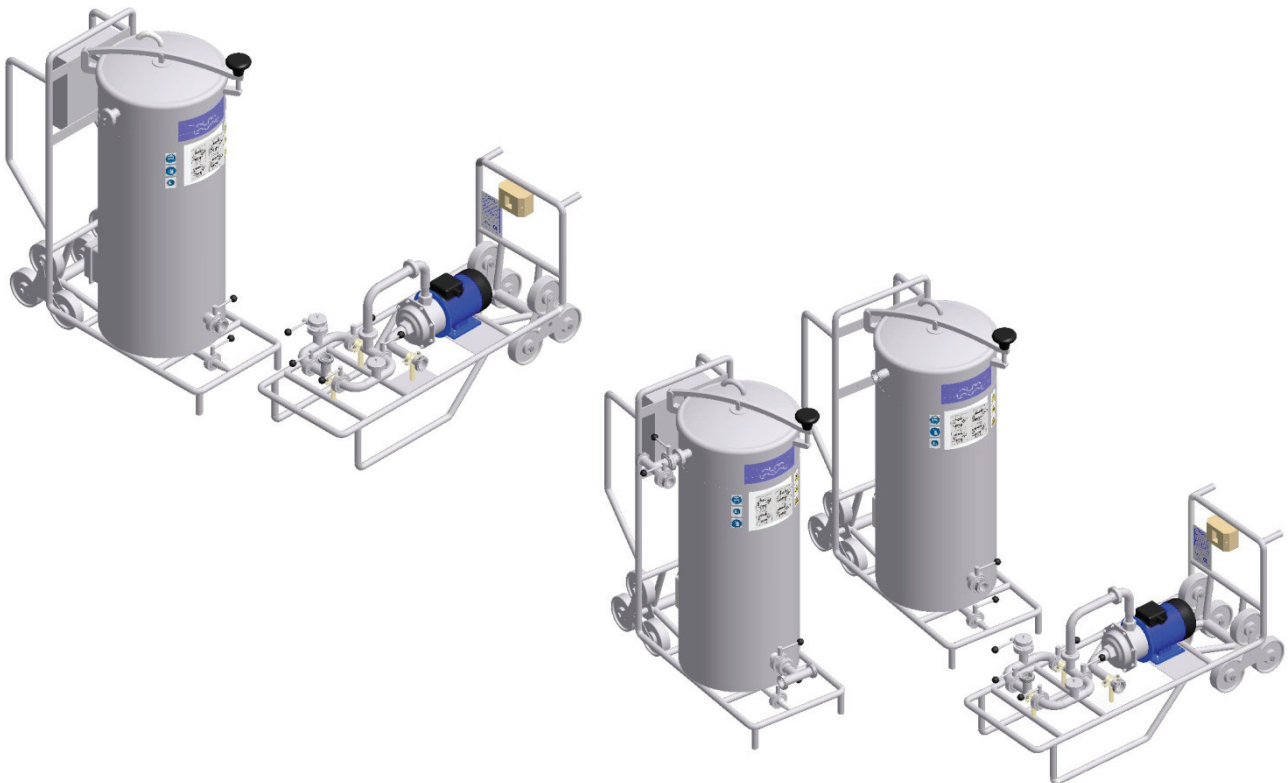

Operating & Maintenance Manual

Cleaning In Place Unit

Model : CIP 200L & 400L
Valid for : CIP 200L & 400L
Manufacturing numbers : 969951-00, 969951-01, 969951-10,
969951-11, 969952-00, 969952-01



Original Manual

ALFA LAVAL COPENHAGEN A/S

English EN



The instructions given in this manual are intended as a general instruction to Alfa Laval CIP units

Alfa Laval reserves the right to make changes at any time without prior notice.

Any comments regarding possible errors and omissions or suggestions for improvement of this publication would be gratefully appreciated. Please forward this information to the address below.

If further clarification regarding this manual is required, please contact your local Alfa Laval representative.

Copies of this publication can be ordered from your local Alfa Laval Company.

Published by: Alfa Laval Copenhagen A/S
Maskinvej 5
DK-2860 Søborg
Denmark

© Copyright Alfa Laval Copenhagen A/S

This manual and its content must not be copied, reproduced, transmitted or disclosed to any third party without consent of Alfa Laval Copenhagen A/S.



Table of contents

1.0.0	FIELD OF APPLICATION	4
2.0.0	SAFETY INSTRUCTIONS AND WARNING	5
2.1.0	<i>General Safety Regulations</i>	6
2.2.0	<i>Safety Regulations during Installation</i>	7
2.3.0	<i>Safety Regulations during Operation and Maintenance</i>	7
2.4.0	<i>Noise Emission</i>	7
2.5.0	<i>Modifications and Reconstruction</i>	7
3.0.0	INSTALLATION GUIDELINES	8
3.1.0	<i>Unpacking</i>	8
3.2.0	<i>Lifting</i>	9
3.3.0	<i>Electrical Installation</i>	10
4.0.0	STORAGE GUIDELINES	11
5.0.0	GENERAL TECHNICAL DATA	12
5.1.0	<i>Technical specification:</i>	12
5.2.0	<i>Equipment list:</i>	12
5.3.0	<i>Valve list:</i>	12
6.0.0	OPERATING INSTRUCTIONS	13
6.1.0	<i>Operating precautions:</i>	13
6.2.0	<i>Operating Principle</i>	13
6.2.1	<i>Start-up preparation:</i>	14
6.2.2	<i>General Operating procedure:</i>	17
6.3.0	<i>Operating procedure</i>	20
6.3.1	<i>Mixing and pre-heating of cleaning liquids</i>	20
6.3.2	<i>CIP-cleaning of the heat exchanger</i>	21
6.3.3	<i>Reverse flow</i>	22
6.3.4	<i>Neutralization</i>	23
6.3.5	<i>Draining of the CIP unit</i>	24
6.3.6	<i>Draining of the heat exchanger</i>	24
6.4.0	<i>Disconnecting the CIP-unit</i>	25
7.0.0	MAINTENANCE	26
7.1.0	<i>Introduction</i>	26
7.2.0	<i>Control Panel</i>	26
7.3.0	<i>Maintenance Interval</i>	27
8.0.0	TROUBLE SHOOTING	28
9.0.0	SPARE PARTS	30
9.1.0	<i>Ordering Spare Parts</i>	30
9.2.0	<i>Alfa Laval Service</i>	30



1.0.0 Field of Application

The Cleaning-In-Place is suitable for cleaning of compact heat exchangers like Gasketed, Welded & Brazed plate heat exchangers, Spiral heat exchangers and Compact tubular heat exchanger.

- Cleaning-In-Place unit has been designed as -
 - An easy & convenient transportable cleaning unit
 - Remove scaling without damaging the plates or gaskets.
 - Increase the lifetime of heat exchanger

2.0.0 Safety Instructions and Warning

The following symbols in this manual point out safety precautions. It means your attention is needed and your safety is involved.



WARNING

This symbol is used to indicate the presence of a hazard, which can or will cause severe personal injury, if the warning is ignored.

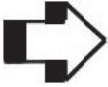







CAUTION

Certain passages of the text will be marked with a caution mark. This mark indicates the presence of hazard, which will or can cause property damage if the instructions are not observed.

NOTE

This type of instruction indicates a situation, which, if not avoided, could result in damage to the equipment.

Equipment is delivered with following signs:





<u>Requirements signs</u>		<u>Warning signs</u>	
	Always use protective foot wear		General warning
	Always use eye protection.		Dangerous electrical voltage
	Always use protective handwear.		Caustic agents
			Hot surface

In case sign (s) is not found on the equipment or sign(s) is damaged new ones must be ordered.

2.1.0 General Safety Regulations

The following general safety rules must be followed on every occasion:

- The installation and operating manual contains vital information that must be considered during all handling of the CIP unit. All personnel who are in contact with the equipment must read the operating and installation manual. The operating manual should be kept available near the equipment.
- If the safety regulations are not followed, there is a risk of injuries as well as damage to the machinery and the surrounding environment. If these safety regulations have not been followed, Alfa Laval cannot be claimed responsible.

	WARNING!
	<p>The CIP unit must never be used when there is a risk for poisonous or lethal fumes or vapors to be released from the fouled equipment during CIP cleaning. When connected to the equipment to be cleaned, the CIP unit is being part of an open system why any fumes or vapors being released will be released out into the atmosphere through mainly the tank.</p>
	<p>When any risk of dangerous vapor or gas in the CIP cleaning system, gas detector and protective breathing equipment must be worn.</p>
	Noise hazards
	Cut hazards
	<ul style="list-style-type: none">• Use ear protection in noisy environments.• Do not work under hanging load.• Wear head protection during installation and maintenance of the equipment.• Wear gloves when handling machined parts.



2.2.0 Safety Regulations during Installation

- Only authorized and qualified personnel should carry out the installation.
- All work on the machinery must be performed when it is not in operation and the main power supply is switched off.
- All local regulations regarding transport and lifting must be followed at all times.

2.3.0 Safety Regulations during Operation and Maintenance

- Never put hands, other parts of your body or foreign objects into the machinery without making sure the main supply has been switched off.

2.4.0 Noise Emission

- Noise emission corresponds to the values for the pump mounted.
- The mean sound pressure levels (L_p) measured at as Curve A (ISO 1680 standard).
- The noise values were measured with 50 Hz motor running idle with a tolerance of 3 dB(A).
- $L_p < 70$ dBA

2.5.0 Modifications and Reconstruction

Please note that the machinery must not be altered or modified in any way if not directly approved of by Alfa Laval.

Use of original spare parts and accessories guarantee a safe operation. Use of parts from other manufacturers can lead to premature failure of the machinery, cause damage to the machine and surrounding area and jeopardize the warranty.

3.0.0 Installation Guidelines

For details on Dimensions, Connections, Service area, etc.: See the order specific dimension drawing.

The CIP unit is delivered as complete machine ready to bring into service.

Check and assemble the hoses carefully between CIP-unit and heat exchanger.

All electrical installations must be done in accordance with local regulations. A certified electrician should carry out this job.

During working on the electrical installations the main power supply must be shut off at all times.



WARNING

Emergency stop must be installed as per local regulations.

3.1.0 Unpacking

When unpacking, take care not to damage the CIP unit.

- Check the delivery. Make sure that the CIP-unit with accessories is complete according to packing list and orders.
- Check the tank. The inlets and the outlets must be free from possible packing materials.
- Verify all electrical connections are intact.
- Make sure that the CIP unit has not been damaged during the transport.
- If transport damages are found, please contact local Alfa Laval agent.
- Alfa Laval cannot be responsible for incorrect unpacking & handling of CIP unit.

3.2.0 Lifting

The CIP unit should only be lifted by using lifting slings fitted according to the following illustrations.

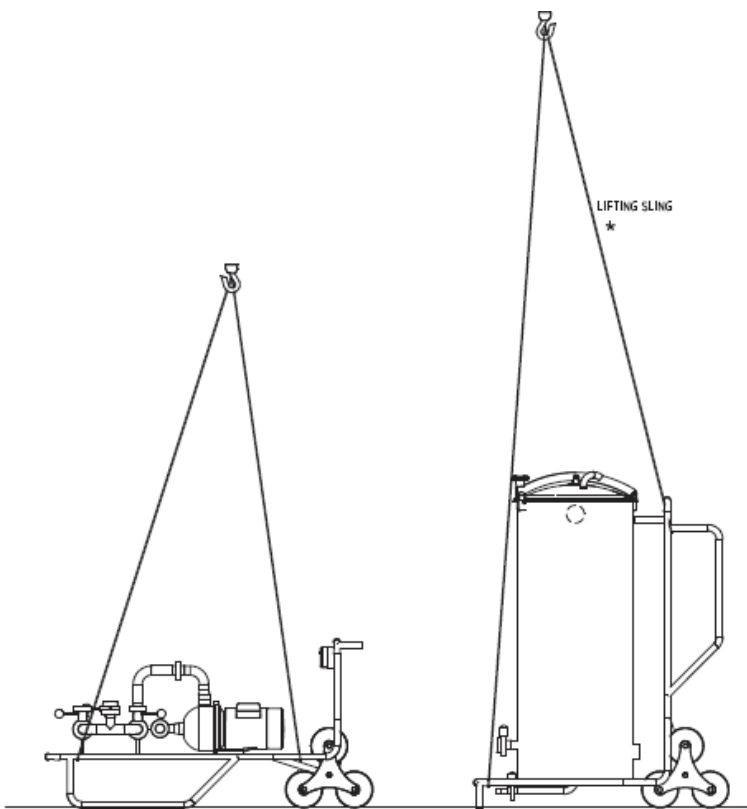
	<p><u>CIP 200L and 400L</u></p> <ol style="list-style-type: none"> 1) Place lifting slings around tank as shown in the drawing carefully, see how the tank, Pump trolley balances. If the trolleys do not balance move lifting slings closer to tank and pump respectively and lift carefully. 2) Repeat procedure until the trolleys gets balance. <ul style="list-style-type: none"> • To lift Tank trolley place lifting slings through the tank frame close to heater. • Cross check that slings are not touching the heater .Place second sling through frame handle close to tank make sure that it is close towards tank to provide Locking system. • To lift Pump Trolley place slings through frame close to pump and place second sling close to valve cluster.
--	---

Always use approved equipment for the lifting. Refer to dimensional drawing for the specific CIP unit for the weight of the equipment.

When lifting a CIP unit, then use proper and approved rope slings and make sure that the CIP unit is prevented from tilting or rotating.

The CIP unit must be completely empty during lifting or transportation in order to avoid unstable lifts and damage to the CIP unit.

**WARNING**

Always use lifting slings of appropriate strength and dimension to handle the weight of the CIP unit.

Always lift the CIP unit by the lifting points, as shown above.

Operators should avoid lifting of heavy components.

3.3.0 Electrical Installation

All electrical installations must be done in accordance with local regulations. A professional electrician should carry out this job.

Apart from the fact that the electrical installation must be effected in a safe, proper and approved way, the different methods of how to regulate the equipment should be considered.

Please refer to 'Start-up preparation' in the below sections and decide how to adapt the electrical installation to the means of operating the machinery.

During working on the electrical installations the main power supply must be shut off at all times.

- The power supply is in accordance with the technical data for the unit. (see the type tag on the motor and heater)
- That electrical hooks-up are connected correctly.

**WARNING**

Failure to comply with electrical regulations can cause risk of death by touching electrified parts.



4.0.0 Storage guidelines

Unless otherwise agreed, Alfa Laval delivers the equipment ready to be put in service upon arrival and after installation.

If it is necessary to store equipment for a longer period, certain precautions should be made in order to protect and prevent unnecessary wear of the equipment.

Often the best solution is to leave the equipment in the packing until installation will occur. In this case Alfa Laval should be informed and proper type of packing should be ordered.

- Do not store the liquid more than a week in CIP tank. Drain and rinse all other equipment after finished CIP cleaning.
- Store hoses and other accessories in dry area protected from physical damage after disconnecting it from CIP-unit.

NOTE

- There should absolutely not be any ozone producing equipment in the storage room, like operating electric motors or arc welding. Ozone destroys many rubber materials.
- Do not store organic solvents or acids in the storage room.
- Do not store the module in wet area.
- Avoid heat and ultraviolet radiation.

If the equipment is stored outdoor, the precautions mentioned above should be taken as far as possible. The need for protection against the climate is more important in this case.



5.0.0 General Technical data

5.1.0 Technical specification:

Refer the General technical data in Technical documentation.

5.2.0 Equipment list:

Refer the General technical data in Technical documentation.

5.3.0 Valve list:

Refer the General technical data in Technical documentation.



6.0.0 Operating instructions

6.1.0 Operating precautions:

Operator should take the following precautions before the operating unit –

- Check the power supply is in accordance with the technical data and make sure that electrical hooks-up are connected correctly.
- Pump should rotate as indicated with the arrow on the housing of the pump.
- Pump's trolley is in horizontal position when pump is in operation.
- Never start the pump or heater without liquids in the tank.
- The cleaning liquid to be used is in accordance with the cleaning procedure to be carried out. (Refer section "Cleaning liquids procedure and ordering")
- Check the temperature during the operation. It should not exceed 85°C. It can be done by opening the lid available on heater & set the position of thermostat to 75°C. (Refer section 6.2.1 for detail instructions)
- Check that all valves are in correct position when starting the unit. (Please refer functional drawing)
- The heat exchanger should not be under pressure when starting the process.
- The heat exchanger should be isolated from the normal system.

6.2.0 Operating Principle

Alfa Laval CIP units includes following operations mainly -

- Shut off and drain the heat exchange to be cleaned.
- Connect the CIP unit to the heat exchanger.
- Mix the cleaning agent with water in the tank and heat it up to specified temperature.
- Circulates the cleaning solution for specified time.
- Drain the cleaning solution and rinse the system with clean water.
- Disconnect the CIP unit.

6.2.1 Start-up preparation:

- **Heater**

Make sure the heater is in Off-position before connecting the power.

Check that the thermostat is in the correct position. The most effective cleaning interval is between 50 to 70°C. Check the temperature during the operation. Use the positioner to set the require temperature. It must never exceed 85 °C.



For 50Hz - The black button will start the heating device. Push the red button to shut-down the Heating device.



For 60 Hz - Make sure the main switch of the heater panel is in 0-position before connecting the power. Put the hand auto switch to 0, to stop the heating. Putting the switch to auto, starts the heating with temperature control, setting it to hand, starts the heating without temperature control.



The thermostat incorporated in the heater regulates itself. The safety thermostat (in the heater) will switch off the heater, in case of over temperature.

- **Pump**

Check rotation of the pump by watching an arrow on the fan cover. The pump should rotate counter clock wise when seen from the motor fan. If it is incorrect: switch 2 phases. Trolley's pump must be in horizontal position during operation. Start the pump.



Push the black button on the pump Starter.





- **Tank**

The volume of the tank is 246 liters. The unit has an effective volume of 200L & 400L respectively.



WARNING

Never fill the tanks above these limit volumes.



6.2.2 General Operating procedure:

6.2.2.1 Operation of valves:

Pull the handles outwards while rotating them.

When valve V05 is in a position between “Open valve” and “Closed valve”, the flow is reduced. To operate this valve, turn the handle and rotate it.

This unit is supplied with a valves arrangement.

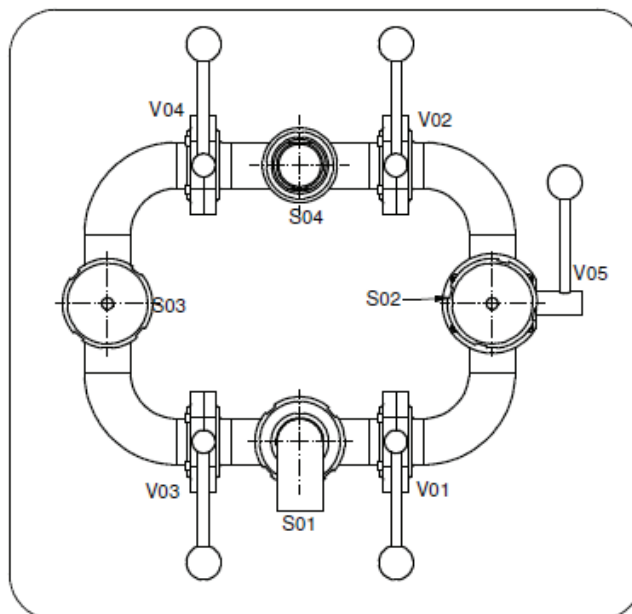
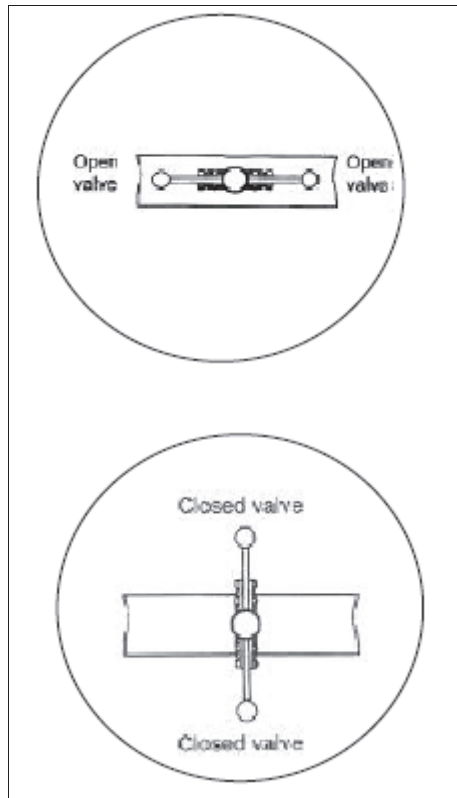



6.2.2.2 Recommendations & Calculations:

- The operation of valves can be done while the CIP-pump is in operation, whenever the flow is always in circulation.
- After starting the pump, set Valve V05 at the pressure side to reduced flow.

STEP 1

- Drain out the fluid from the heat exchanger.
- Assemble the hoses between the CIP unit and the heat exchanger. And place the pump in horizontal position.

STEP 2

- Fill the tank with required volume of water via the filling pipe (use hot water if available maximum 85°C).

- **For correct volume you need to calculate the total volume.**

$v_{\text{Water}} = v_{\text{Total}} \times \text{Partcleaning liquid}$
$v_{\text{Total}} = v_{\text{HE}} + v_{\text{Hoses\& piping}} + v_{\text{Pump\& heater}}$

v_{Total} =required volume (including cleaning liquids)
 v_{HE} = Volume in heat exchanger for the side that will be cleaned.

For Plate heat exchanger = (volume per channel) x No of plates / 2
--

$v_{\text{Pump\& heater}}$ =Min. volume for CIP 200L in order not to dry out the pump and the heater, in closed circuit, excluding PHE is approx. 52 litres.

$v_{\text{hoses\& piping}}$ = There are 4 hoses in CIP 200L,
The total volume = Approx. 20 litres.

→ The piping volume can vary depending on heat exchanger pipe diameter and pipe length between CIP connection and PHE.

- **Instructions of use for the cleaning chemicals -**

- Mixing ratio = 1 part Cleaning liquid to 9 parts of water
- If the total volume is 120 litres then

$\text{VolumeWater} = 120 / 10 \times 9 = 108 \text{ litre}$
$\text{VolumeCleaning liquid} = 120 / 10 \times 1 = 12 \text{ litre}$

- Mixing ratio = 1 part Cleaning liquid to 4 parts of water
- If the total volume is 120 litres then

$\text{VolumeWater} = 120 / 5 \times 4 = 96 \text{ litre}$
$\text{VolumeCleaning liquid} = 120 / 5 \times 1 = 24 \text{ litre}$



- Add calculated amount of cleaning liquids, see calculation above. (For the different cleaning liquids mixing ratio, see section “Cleaning liquids procedure and ordering”)

STEP 3

- Connect power to the pump. (3 phases + ground)

STEP 4

- Connect power to the heater. (3 phases + ground)

6.3.0 Operating procedure

- Different operations of CIP module:

6.3.1 Mixing and pre-heating of cleaning liquids

Turn the valves to position according to below description. And assemble the hoses according to P&ID Diagram.

That means:

Valve tag number	Status
Valve V01	Open
Valve V02	Open
Valve V03	Closed
Valve V04	Closed
Valve V05	Closed

1. Mixing and Pre-Heating of cleaning liquids

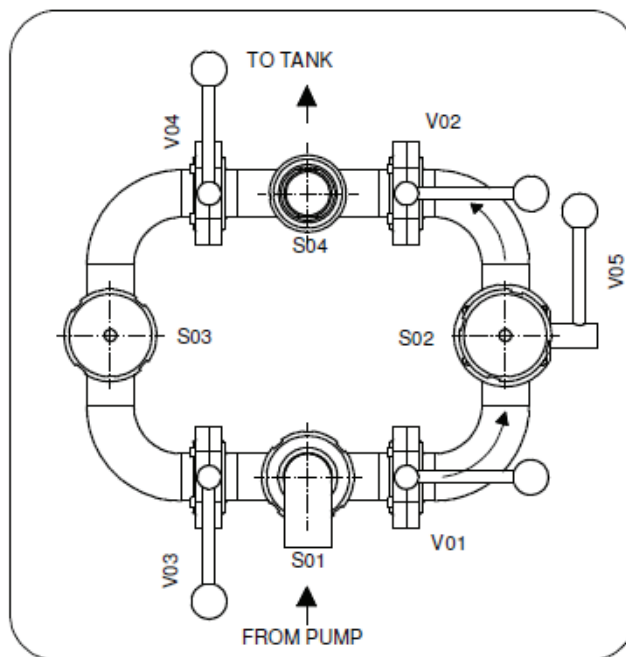

The operation of valves can be done while the CIP-pump is in operation, whenever the flow is always in circulation.

Start the pump with the black push button on the pump

Select desired temperature on the heater (recommended interval is 50-70°C) and start the heater with the black start button.

To heat up 200 litres from 20°C to 70°C will take approximately 2 hour with 6 kW and 1 hour with 12 kW.

6.3.2 CIP-cleaning of the heat exchanger

Turn the valves to positions according to below description.

That means:

Valve tag number	Status
Valve V01	Closed
Valve V02	Open
Valve V03	Open
Valve V04	Closed
Valve V05	Open

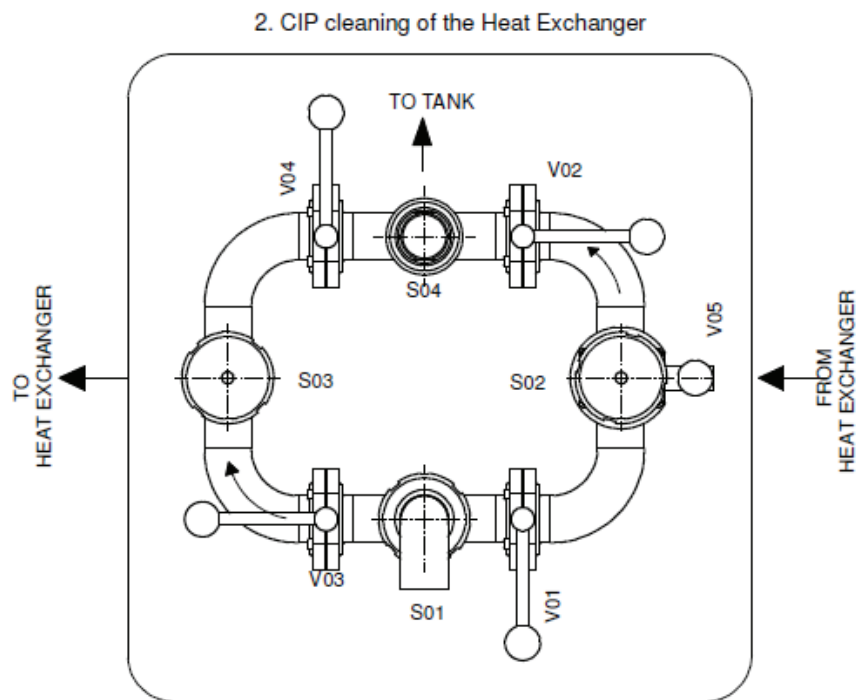

Regulate the flow with V05 if necessary.

When the cleaning is finished: Stop the pump and switch off the heaters.



6.3.3 Reverse flow

If your heat exchanger is fitted with only one grouping, (see the heat exchanger drawing) go to “Neutralization”

If your heat exchanger is fitted with multi pass grouping it is necessary to change the flow direction after half of the recommended operation time specified in the CIP-cleaning.

Adjusting the valves according to below description changes the flow direction through the PHE.

That means:

Valve tag number	Status
Valve V01	Open
Valve V02	Closed
Valve V03	Closed
Valve V04	Open
Valve V05	Open

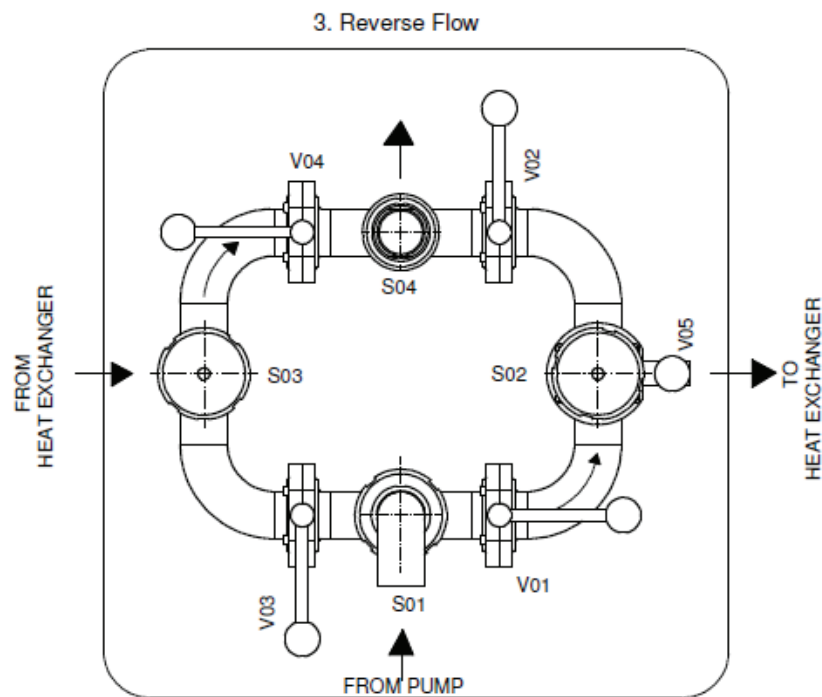

Regulate the flow with V05 if necessary.

When the cleaning is finished: Stop the pump and switch off the heaters.

6.3.4 Neutralization

Some Cleaning liquids require neutralization prior to disposal. (Refer Cleaning liquids procedures)

If the cleaning liquid is to be re-used do not neutralize it.

The neutralization process is done by adding the neutralization liquid to the cleaning liquid in accordance with the separate instruction for neutralization liquids.

Stop pump and heater before adding the neutralization liquid. Turn the valves to position according to below description.

That means:

Valve tag number	Status
Valve V01	Open
Valve V02	Closed
Valve V03	Closed
Valve V04	Open
Valve V05	Open

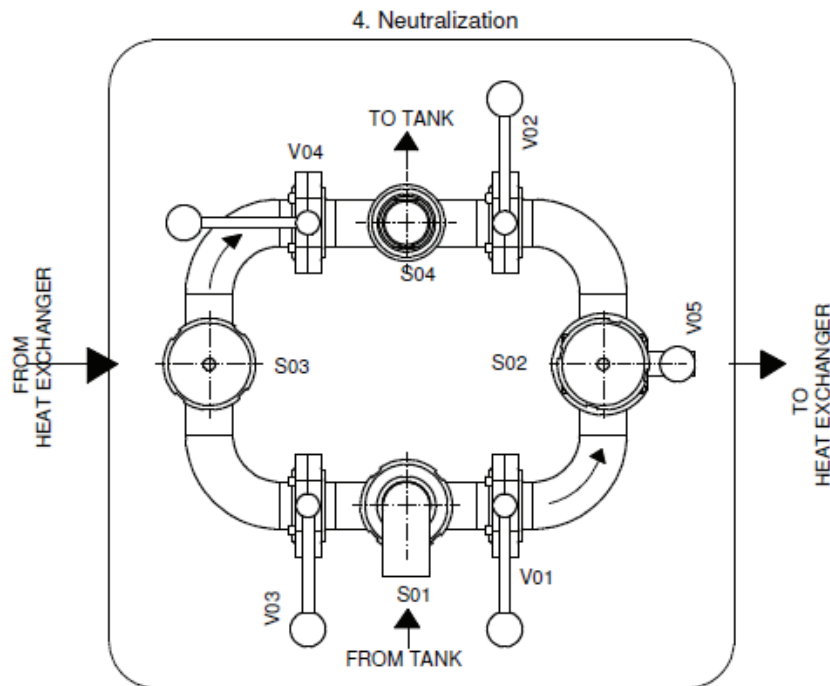

Start the pump.

The circulation of the fluid is maintained until the “used” cleaning liquid has obtained a pH value of 6.5 to 7.5. The neutralization process may take about 1 hour to complete.



6.3.5 Draining of the CIP unit

- Open V01-V04 valves on the CIP unit.
- Connect the drain of the CIP tank to a suitable barrel.
- Open the drain valve V06 on the tank and drain the unit completely.
- Close all valves after the draining.

6.3.6 Draining of the heat exchanger

- Disconnect the hose from the CIP unit that is fitted to the lower connection on the heat exchanger.
- Place the end of the hose in a barrel to a collection vessel.
- Disconnect the hose from the CIP unit that is fitted to the upper connection of the heat exchanger.
- Drain the heat exchanger

It is recommended to flush the heat exchanger with the normal system after CIP if possible. This will remove any particles that need mechanical removal.

6.4.0 Disconnecting the CIP-unit

STEP 1 -

When disconnecting the hoses from the CIP-unit, inspect them for visible damages. Avoid damaging the electrical cables, or the inlets and outlets of the unit.

STEP 2 -

Turn the valves to position according to mixing and pre-heating.

That means:

Valve tag number	Status
Valve V01	Open
Valve V02	Open
Valve V03	Closed
Valve V04	Closed
Valve V05	Closed

5.Disconnecting CIP unit

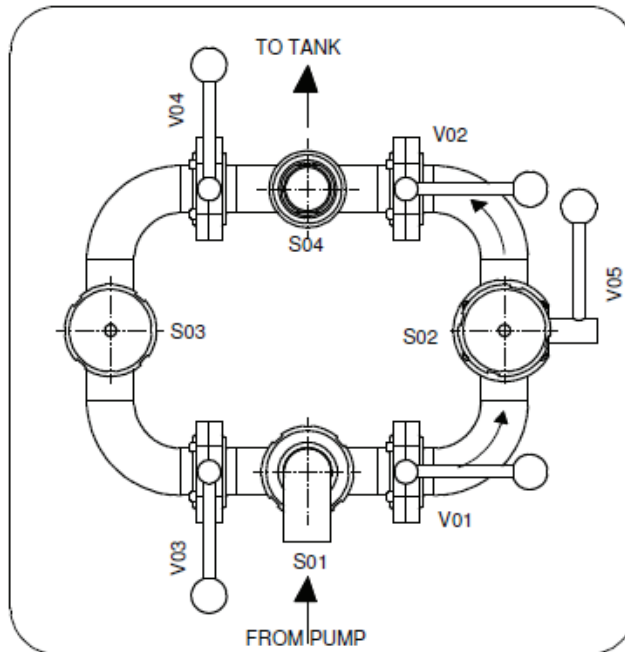

Fill the tank to 1/3 with fresh water. Start the pump for about 3 minutes. Stop the pump.



7.0.0 Maintenance

7.1.0 Introduction

The CIP unit only requires very little maintenance. However following the maintenance instructions will ensure performance and availability.

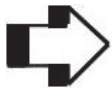

CAUTION

Always follow recommendations on maintenance and service specified in the specific manuals for each component.

After disconnecting the CIP-unit -

- Flush the hoses manually with fresh water.
- Store hoses and other accessories in a dry area protected from physical damage.
- Open V06 and rinse the tanks with fresh water.
- Take out the sieve (filter) inside the tank and rinse with fresh water.



7.2.0 Control Panel

Switch off the main power supply to the control panel prior to opening the panel. For control panels with more than one CIP unit control, switch of safety switch at the CIP unit.

CIP units equipped with **electric actuators**:

Switch off safety switch on the junction box, before attempting to do any maintenance or repair.



WARNING

Ensure that the main power source is switched off before attempting to disconnect the control panel.



7.3.0 Maintenance Interval

The CIP unit should be opened once a year for inspection, ease of operation, and checking its condition by a skilled / certified technician under the supervision of maintenance manager

- Check operation and condition of the all valve.
- When disconnecting the hoses from CIP unit, inspect them for visible damages.
- Avoid damaging the electrical cables or inlets & outlets of the unit.
- Check the conditions of pump seal.
- Heating elements are to be checked for its conditions.



8.0.0 Trouble Shooting

Problem	Indication	Possible Cause	Remedy
Leakage	In main flanges. (inlet and outlet)	Insufficiently tightened.	Tighten.
		Damaged gaskets.	Open and check, change and repair if necessary.
	Valve leakage.	Incorrect assembly or damaged rubber seat. Valve body cracked or Broken.	Remove valve and check the rubber seat or foreign particle or misalignment, if not, reassemble valve. If valve body cracked or broken, replace the valve with new valve.
	Shaft seal leakage	Dry run of pump Incorrect rubber grade Abrasive particles in the liquid	Replace: All wearing parts (see drawing /parts list) Select a different rubber grade Select stationary and rotating seal ring in Silicon Carbide/Silicon Carbide
Pump cavitation	Pressure reduction. (At times to zero)	Low inlet pressure High liquid temperature	Increase the inlet pressure Increase the liquid level Reduce the liquid temperature
Overloaded motor		Pumping of viscous liquids Pumping of liquids with high density Low outlet pressure (counter pressure)	Change impeller Higher counter pressure (throttling)



Problem	Indication	Possible Cause	Remedy
CIP unit does not operate.	No indication.	No power supply.	Check external power source & turn on the main power switch.
CIP unit clogged.	High pressure drop Decreased water flow.	CIP unit blocked with too much debris.	Shut down the CIP unit, open end cover and clean the CIP unit manually. See "Maintenance interval"



9.0.0 Spare Parts

For every CIP unit delivered a number of spare parts are available. Please refer to the CIP unit specification delivered with the given CIP unit.

9.1.0 Ordering Spare Parts

When ordering spare parts, please always state:

1. Machine number (see name plate)
2. Designation (Type of component, supplier and serial number)
3. Capacity or other relevant identification
4. Article number / Spare part number (from CIP unit specification)

Also please refer to the specific manuals for the components to identify spare parts.

9.2.0 Alfa Laval Service

Please contact your local Alfa Laval agent for Parts and service questions.