

Design for Additive Manufacturing

Zander Oksavik Bratland og William Austrheim
Fakultet for ingeniør- og naturvitenskap

> EXPO nr. M11

Objective

- Four cases, three engine parts and one tool redesigned for additive manufacturing
- Weight saving and part consolidation in focus
- The redesign shall satisfy strength requirements, while retaining stiffness

Method

- Case definition
- Model preparation
- Optimizing process
- Evaluating result

Additive Manufacturing process

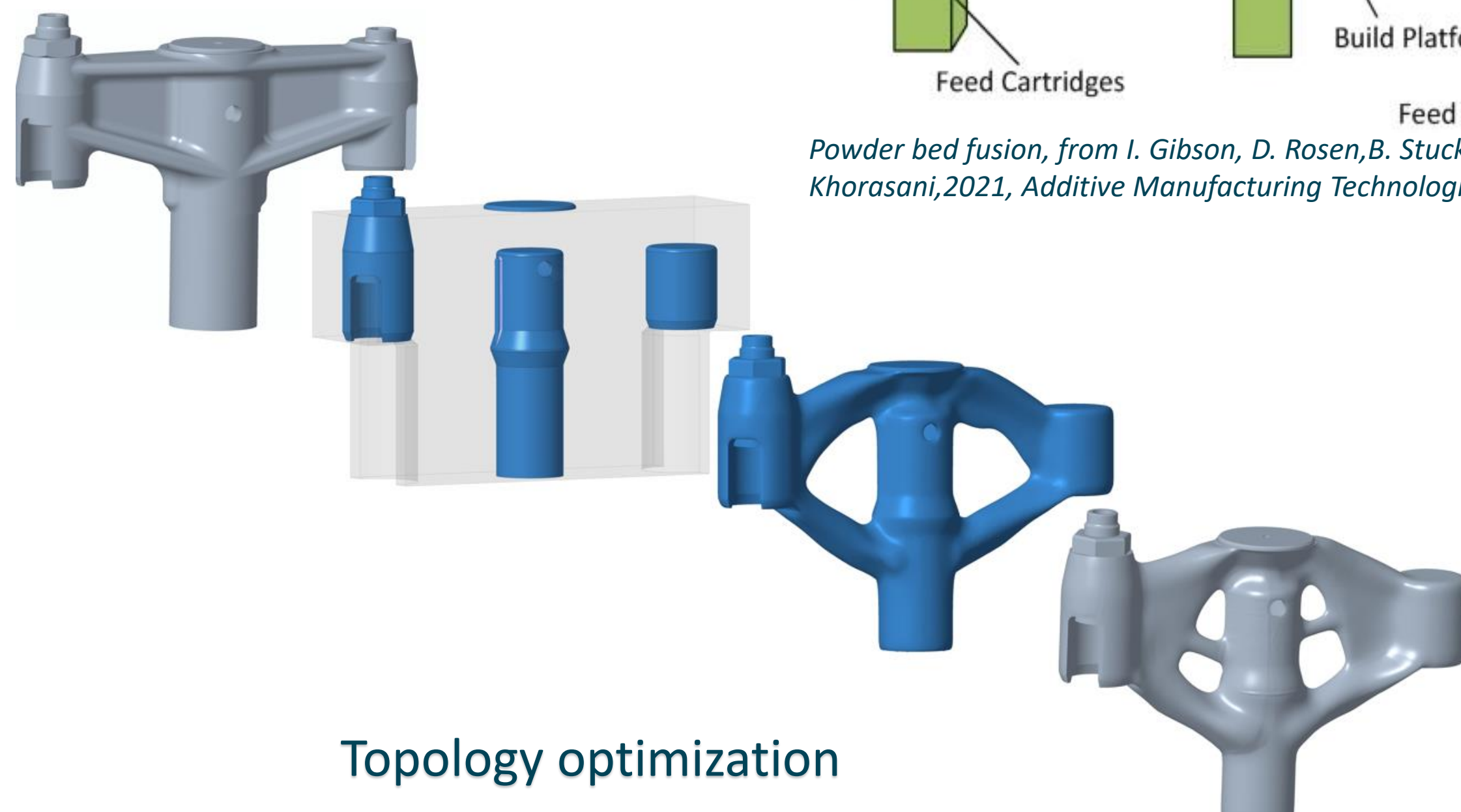
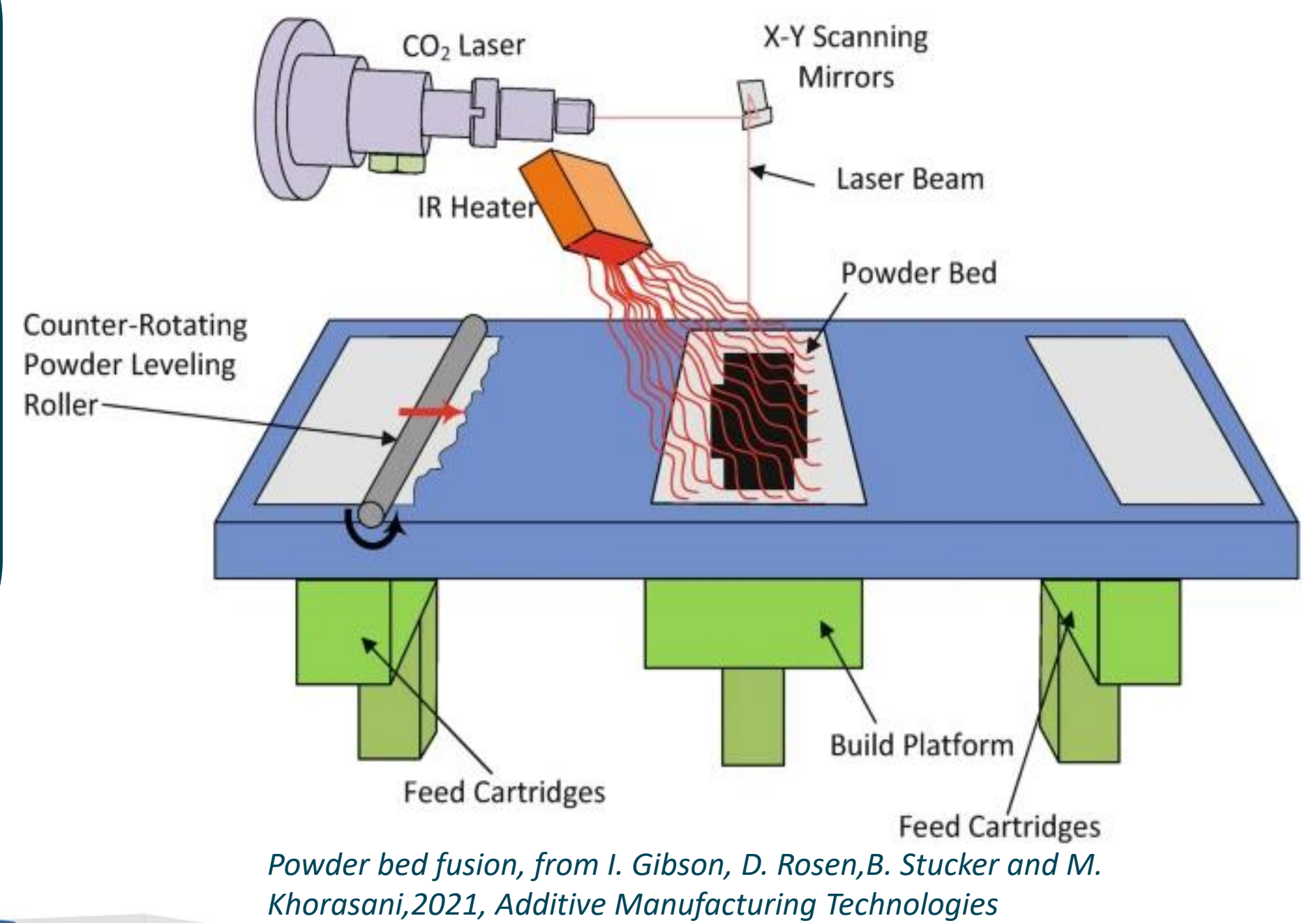

Results

Case 1: A lightweight, manageable lifting tool made with AlSi10Mg.

Case 2: Nozzle holder housing, 55% less weight and material usage with lattices

Case 3: Multimaterial cam follower injection pump with increased fatigue life

Case 4: Valve bridge with lower weight and simplified design



Case 1



Case 2



Case 3

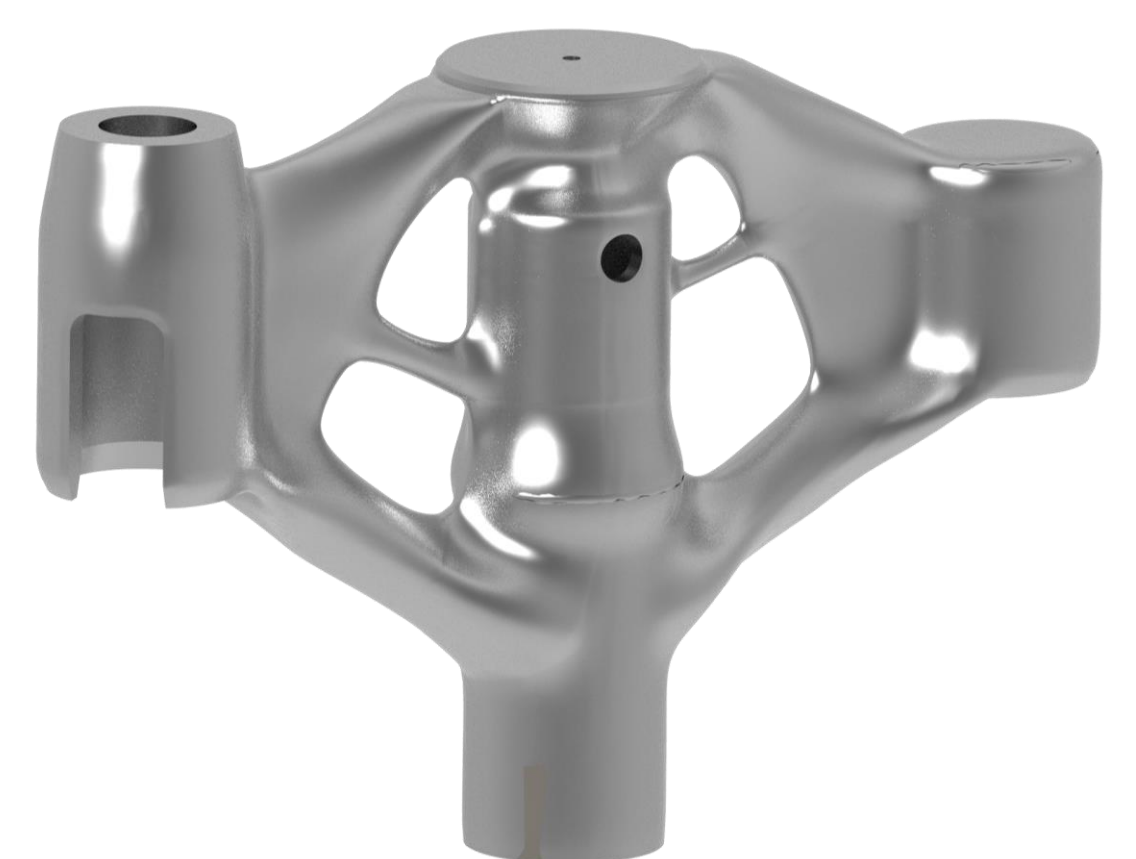

Case 4