

# Hydraulic Retrieval of Plugs in Tubing Hanger

Bachelor thesis by Anni Skåtun, Aurora B. Loftesnes & Ingrid S. Mjaatvedt

Department of Mechanical- and Marine Engineering

M94



Will it be advantageous for TechnipFMC to implement a retrieving tool for retrieving plugs in Tubing Hanger hydraulically, compared to the current method where mechanical force is used?

In collaboration with TechnipFMC, an improved method of retrieving plugs in Tubing Hanger at their test centre has been developed. The current method, where mechanical force is used, is exhausting and ergonomically poor. Therefore, we investigated the possibilities of retrieving the plugs hydraulically.

The final design of the HRT is 3 shafts connected with threads. By using Ansys simulation program, the HRT was designed, simulated and calculated to withstand the required force.

Comparative risk analyses were performed on both the current method, and the new method using the HRT, such that the improvement in risk from high to low was clarified.

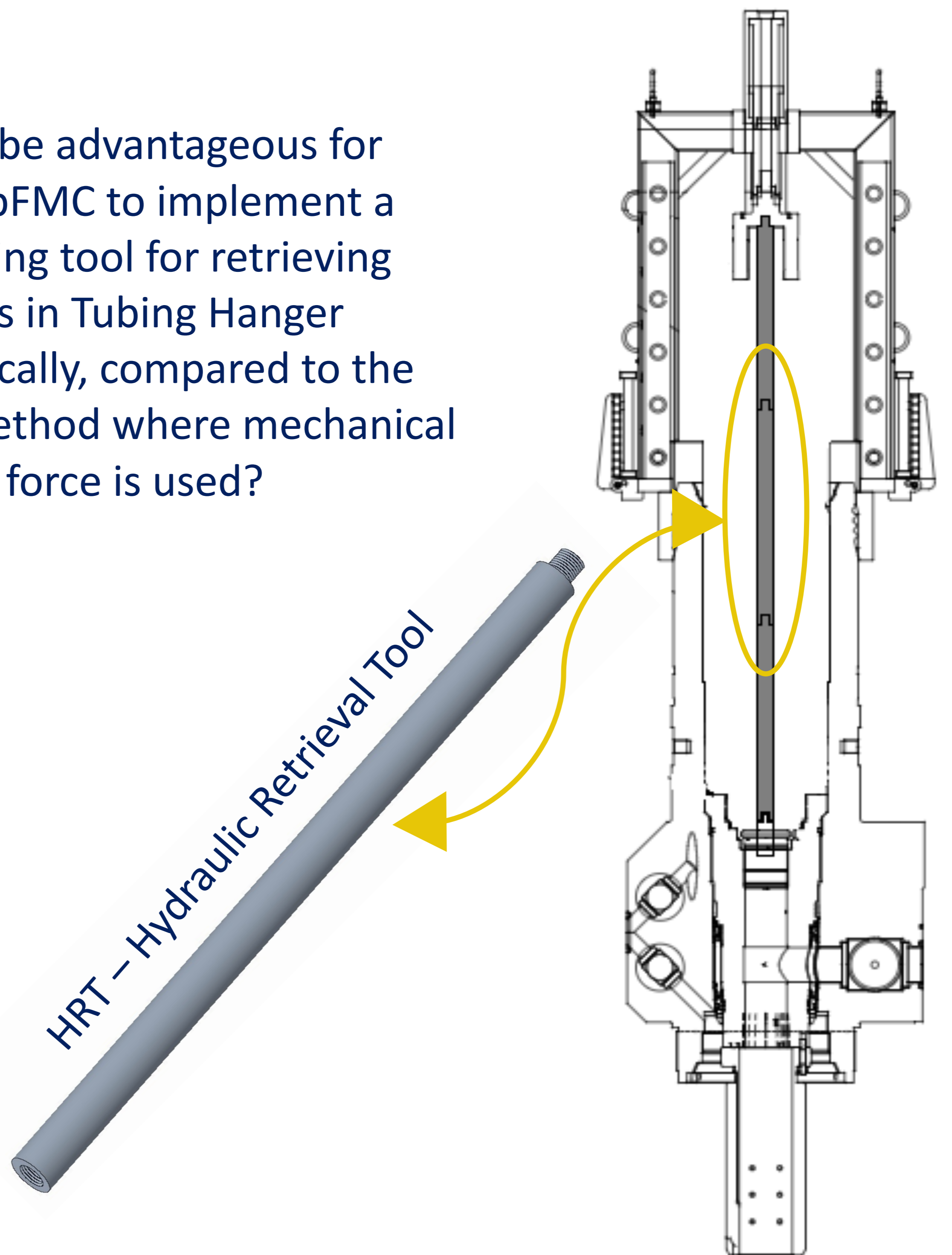

## Current method:

Likelihood	Consequence				
	Insignificant	Minor	Moderate	Major	Severe
Almost Certain	Medium	High	High	Extreme	Extreme
Likely	Medium	Medium	High	Extreme	Extreme
Possible	Medium	Medium	High	High	Extreme
Unlikely	Low	Medium	Medium	High	High
Rare	Low	Low	Medium	High	High

## New method:

Likelihood	Consequence				
	Insignificant	Minor	Moderate	Major	Severe
Almost Certain	Medium	High	High	Extreme	Extreme
Likely	Medium	Medium	High	Extreme	Extreme
Possible	Medium	Medium	High	High	Extreme
Unlikely	Low	Medium	Medium	High	High
Rare	Low	Low	Medium	High	High

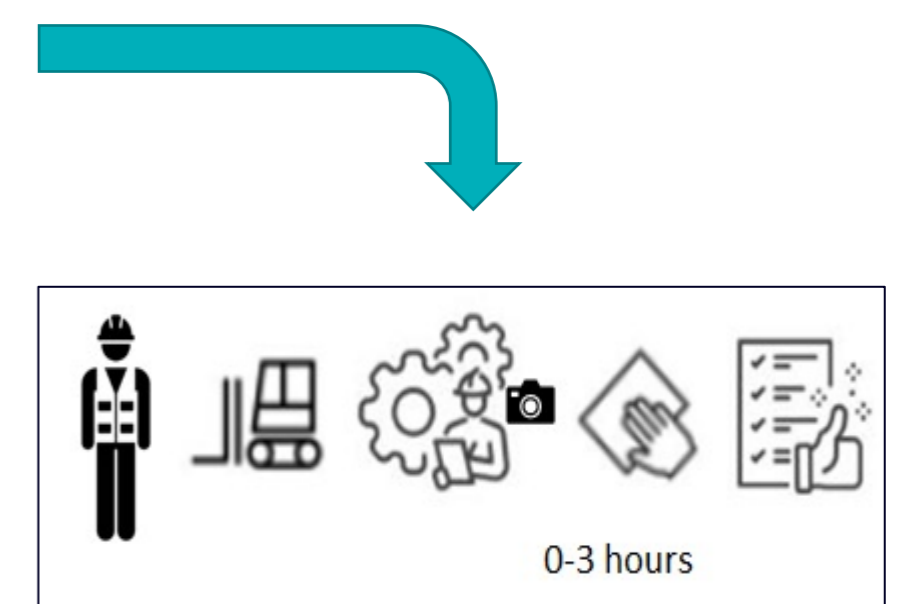
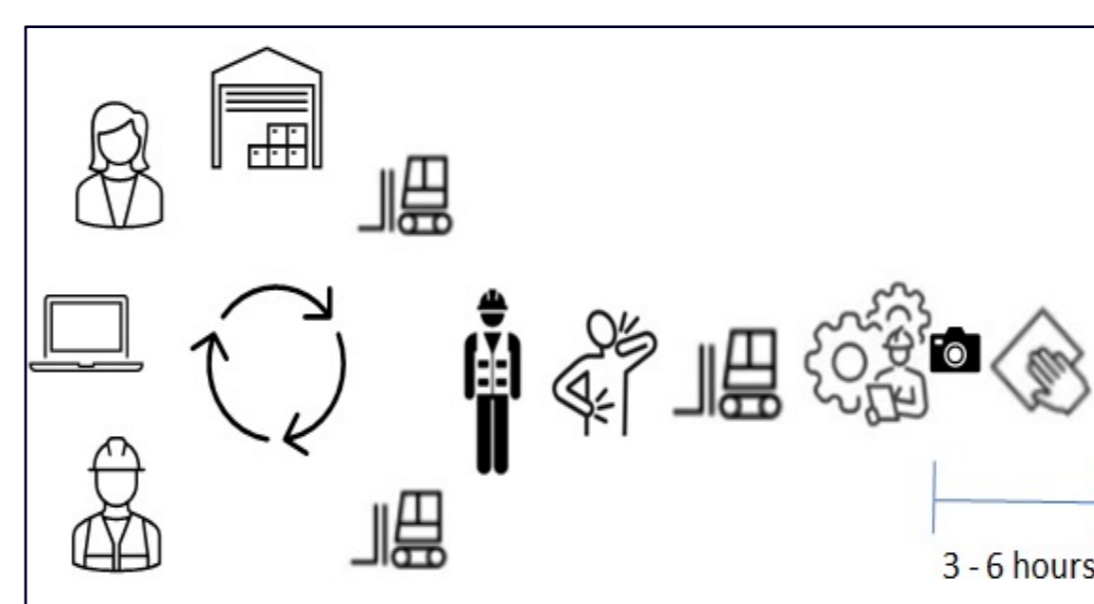

By implementing the HRT in the retrieval of plugs, TechnipFMC will save on both logistics and working hours, as well as the ergonomic and safety of the workers will improve.

**Investment costs: 35 076 NOK**

**Yearly savings: 63 670 – 695 110 NOK**