



Western Norway  
University of  
Applied Sciences

# BACHELOR'S THESIS

Construction with engineered timber  
Focus on environmental exposure and  
wetting risks during construction

by

**Luka Naumovski**

Department of Civil Engineering

Bygg

Loftur Thor Jonsson

22.05.2019

I confirm that the work is self-prepared and that references/source references to all sources used in the work are provided, cf. Regulation relating to academic studies and examinations at the Western Norway University of Applied Sciences (HVL), § 10.

## Preface

This study presents the final bachelor thesis at the civil engineering department at the Western Norway University of Applied Sciences (HVL), campus Bergen. The thesis is written by Luka Naumovski, as part of a student exchange program between the University of Ljubljana, Slovenia and the Western Norway University of Applied Sciences.

As wood is our only widely used building material that is truly renewably, and therefore sustainable, the current ongoing project in Bergen called *Skipet* or “The ship” immediately draw my attention. It is a project that is going to be built from 100% wood, which instantly creates great challenges in terms of design and static analysis. However, what astonished me was building such an enormous timber construction without a temporary roof in such a rainy climate, in Bergen. In order to better understand the process of building I decided to broaden my horizon in this area and do a research on how exposure and wetting during construction affects different kind of engineered wood products or timber systems and primarily try to realize how we should protect them.

Lastly, I would also like to express my gratitude to my mentor Loftur Thor Jonsson, who guided me through the process and contacted the parties involved in the *Skipet* project.

*Luka Naumovski*

*Luka Naumovski*

*Bergen, May 2019*

## ***Summary***

The pursuit for sustainable, environmentally friendly and climate-neutral methods of constructing leads to an increasing acceptance of a material - wood. Therefore, it is clearly that the use of renewable energy sources and materials should be emphasized, which would theoretically make it possible for homes and offices to become carbon neutral. In addition, the only building material that is carbon negative and is widely available is timber and the construction products made from it. Due to the hygroscopic nature of wood and other mass timber products, they are facing various risks while construction - from volumetric changes and moulds or fungus to structural damage.

With the increase in building height and area, which prolongs the exposure to the environment, and the increase in speed of construction that unables longer time for drying, the construction moisture management is becoming increasingly important no matter the fact that wood is in general quite resilient to moisture content changes if kept within certain limits. For this reason, a series of standardized on-site moisture safety activities must be carried out.

For the purpose of better understanding the process of the standardized activities, a visit to the local building site of the *Skipet* project was organized, and later-on used as reference. It is worth to mention that other mass timber projects and their on-site moisture management agenda were also analyzed. From the study it is determinated, that longer mass timber and especially CLT construction without temporary roof or damage should be considered possible for future projects, nevertheless it is a high-risk activity in rainy climates or seasons and requires precaution.

## ***Abstract***

This study is focused on construction with engineered timber and the impact that exposure and wetting during construction has on its properties. It tries to introduce and discuss moisture safety principles and successful on-site moisture management agenda.

Different construction types and products are introduced in order to analyze and better understand moisture's influence, which according to the gathered data emphasizes cross laminated timber as the most widely used and fragile component for wetting in modern multi-storey timber buildings. Considering the fact, that CLT covers a vast area, especially the exposed horizontal elements and shafts, the outcome should not be a complete surprise. In order to better determine its behavior and response to wetting a separate chapter is dedicated to CLT's production, design, performance and construction process.

Furthermore, the wetting and drying potential of timber products and the on-site moisture content measurement and surveying techniques are as well examined. In addition to the presented protection principles some examples of good pre-planning in the industry are also reviewed, thus including: *Skipet*, *Mjøstårnet* and *Treet*.

Finally, according to the study and found literature, it was revealed that construction without any additional roof or tent is considered as possible in wet periods or climates, however pre-planning and strictly following the required protection principles is crucial.

## Table of Contents

<b>1. Introduction</b> .....	1
1.1 Why wood?.....	1
1.2 Sustainable buildings .....	2
1.3 Aim .....	3
1.4 Objectives .....	3
1.5 Method.....	3
<b>2. Theoretical framework</b> .....	4
2.1 Chapter outline.....	4
2.2 Anatomy and wood properties .....	4
2.2.1 Microscopic structure.....	5
2.2.2 Macroscopic structure .....	5
2.2.3 Wood properties.....	6
2.3 Moisture and physical properties of wood.....	7
2.3.1 General.....	7
2.3.2 Fiber saturation point - FSP .....	7
2.3.3 Moisture content - MC.....	8
2.3.4 Equilibrium moisture content - EMC.....	8
2.3.5 Durability and Biodeterioration .....	9
2.3.6 Dimensional changes .....	9
2.4 Moisture physics .....	10
2.4.1 General.....	10
2.4.2 States of moisture.....	10
2.4.3 Moisture in air.....	10
2.4.4 Moisture storage in materials.....	11
2.4.5 Moisture transport through porous materials .....	13
<b>3. Timber construction and engineered wood products</b> .....	14
3.1 Chapter outline.....	14
3.2 Building systems.....	14
3.2.1 Panel system.....	15
3.2.2 Modular system.....	16
3.2.2 Post and beam systems.....	16
3.3 Engineered wood products and mass timber.....	17
3.3.1 General.....	17
3.3.2 Wood products based on sawn timber boards.....	18
3.3.3 Wood products based on veneers.....	21

3.3.4 Wood products based on strands, chips or fibre .....	22
<b>4. CLT as a building material .....</b>	<b>23</b>
4.1 Chapter outline.....	23
4.2 Market and manufacturers .....	23
4.3 Manufacturing and composition .....	23
4.3.1 Preparation and treatment of material .....	24
4.3.2 Arranging and gluing of material.....	24
4.4 Application.....	25
4.5 Construction.....	26
4.6 Structural design .....	27
4.7 Performance .....	28
4.7.1 Durability performance and moisture behavior .....	28
4.7.2 Fire performance .....	29
<b>5. On-site moisture protection .....</b>	<b>30</b>
5.1 Chapter outline.....	30
5.2 Moisture content measurement .....	31
5.2.1 Resistance method.....	31
5.2.2 Capacitance method .....	33
5.2.3 Measuring average MC and surface MC .....	34
5.3 Wood moisture levels and durability .....	35
5.4 Wetting and drying potentials of EWP .....	37
5.5 On-site moisture management .....	38
5.5.1 General.....	38
5.5.2 Overall on-site weather protection.....	39
5.5.3 Guidelines for different EWP on-site moisture protection.....	42
5.5.4 Guidelines for CLT building assemblies on-site moisture protection.....	42
<b>6. Implementation into reference projects.....</b>	<b>44</b>
6.1 Chapter outline.....	44
6.2 Skipet .....	44
6.3 Mjøstårnet .....	47
6.4 Treet .....	49
<b>7. Conclusion and recommendations.....</b>	<b>52</b>
7.1 Conclusion .....	52
7.2 Recommendations.....	53
7.3 Further work.....	54
<b>8. References.....</b>	<b>55</b>

## Table of figures

Figure 1 Wood as a reusable material [46] .....	1
Figure 2 Microscopic cellular sections of pine wood [57].....	4
Figure 3 Macroscopic structure and sections of wood [7].....	5
Figure 4 The main anisotropic directions: longitudinal, tangential and radial [4].....	6
Figure 5 The relationship between relative humidity and the equilibrium moisture content [4].....	9
Figure 6 The water molecule [54] .....	10
Figure 7 The Psychometric chart [55] .....	10
Figure 8 The Sorption Isotherm [55].....	12
Figure 9 The light frame construction system [36] .....	15
Figure 10 Solid X-Lam elements multi-storey construction system [11].....	15
Figure 11 CLT modular system [11] .....	16
Figure 12 Post and beam- Skelet system [36] .....	16
Figure 13 Glued Laminated timber elements [16] .....	18
Figure 14 Glulam production process scheme [15].....	19
Figure 15 Dowel laminated timber element [9] .....	20
Figure 16 Laminated veneer lumber elements [61].....	21
Figure 17 Production method of veneer products [16] .....	22
Figure 18 Laminated strand lumber [16].....	22
Figure 19 CLT leading manufacturers [6] .....	23
Figure 20 Scheme of CLTs production process [20].....	25
Figure 21 Scheme of a cross laminated timber.....	26
Figure 22 CLT prefabrication and on-site assembly [26].....	26
Figure 23 Stress distribution for CLT element loaded out-of-plane [20].....	27
Figure 24 Cross section of a charred CLT element [14].....	29
Figure 25 Scheme of methods to determine wood moisture content [23].....	31
Figure 26 Commercially available device using the resistance method [23].....	32
Figure 27 Schematic of area measured by resistance method using insulated and non-insulated electrodes [23].....	32
Figure 28 Measuring MC of a CLT panel using a resistance method device [44].....	32
Figure 29 Schematic of area measured by capacitance method and a commercially available device [23] .....	33
Figure 30 Measuring wood moisture content using a capacitance-based meter (left) and a resistance-based meter (right) [21].....	33
Figure 31 Measuring average and surface MC of a timber product according to EN 13183-2 [58] ...	34
Figure 32 Cross-section MC variation .....	35

Figure 33 Isothermal sorption curves –.....	35
Figure 34 On-site moisture safety activities and MC monitoring scheme according to the 4D principle [22] .....	38
Figure 35 Good practices in material delivery [58].....	39
Figure 36 EWP proper on-site storage - scheme [37].....	40
Figure 37 On-site storage of manufacturers' sealed CLT elements – Project: Skipet [by author].....	40
Figure 38 Principles for proper on-site storage of products[58].....	41
Figure 39 Waterproof tarpaulins used as end-grains protection on Glulam columns, while construction – Project: Skipet [by author] .....	41
Figure 40 Illustration of the Skipet project [60].....	44
Figure 41 Construction site of the Skipet project in Bergen. Half of the building is enclosed (right). Protective tarpaulin covers give protection to the end grain of the panels and columns [by author] .	45
Figure 42 CLT and Glulam elements on-site delivery, routine checks and preparation for on-site storage of elements [by author] .....	45
Figure 43 Construction site of the Skipet project in Bergen, material storage location and crane handling .....	46
Figure 44 Observed high-risk locations in the Skipet project; CLT-Concrete connections, covered stains and gaps. No significant damage is found [by author] .....	46
Figure 45 Illustration of the Mjøstårnet project [30].....	47
Figure 46 Construction site of the Mjøstårnet project. Installation of the pre-assembled Glulam structure and CLT shafts [61].....	47
Figure 47 Installation steps with time intervals in the Mjøstårnet project [61].....	48
Figure 48 Plastic covers as end-grains protection [30].....	49
Figure 49 Illustration of the Treet project [63].....	49
Figure 50 Construction site of the Treet project. Installation of the prefabricated modules [62].....	50
Figure 51 Construction site of the Treet project. Installation of the pre-assembled Glulam structure and CLT shafts with the tower crane and scaffolding system [62].....	51
Figure 52 Protective plastic covers give protection to the end-grains of the Glulam columns (left). Installation of CLT elevator shafts (right) [63] .....	51



**Table of tables**

<i>Table 2- 1 Properties variations caused by change of MC for 1% [10] .....</i>	<i>7</i>
<i>Table 2- 2 Moisture storage in materials [55] .....</i>	<i>12</i>
<i>Table 2- 4 Moisture transport through porous materials [55].....</i>	<i>13</i>

## ***Nomenclature***

### ***Abbreviations***

<i>CLT</i>	Cross laminated timber
<i>GLULAM</i>	Glued laminated timber.
<i>RH</i>	Relative humidity.
<i>FSP</i>	Fibre saturation point.
<i>MC</i>	Moisture content.
<i>EWP</i>	Engineered wood products.
<i>LCA</i>	Life cycle assessment
<i>NLT</i>	Nail laminated timber
<i>DLT</i>	Dowel laminated timber
<i>LVL</i>	Laminated veneer lumber.
<i>LSL</i>	Laminated strand lumber
<i>OSB</i>	Oriented strand board

### ***Definitions***

<i>Fibre saturation</i>	Cell walls are saturated with water. Around RH 100%.
<i>Hygroscopic</i>	The ability to accumulate and release moisture due to change in the surrounding-air humidity.
<i>Hygrothermal</i>	The combination between moisture and heat.
<i>Tracheids</i>	Wood cells that provide strength and help in water transport.
<i>Exposure protection</i>	Common and temporarily protection against the outdoor climate of a building during construction.
<i>Temporary roof</i>	A roof over the building during construction.
<i>Wetting</i>	In this context results from exposure to liquid water, such as rain and snow, if melted.
<i>Hydroxyl groups</i>	A hydroxyl group is a pair of atoms that is commonly found in organic compounds, such as sugars.
<i>Van der Waals forces</i>	General term used to define the attraction of intermolecular forces between molecules.
<i>Isotherm</i>	A curve-line on a diagram joining points representing states of equal temperature.

*“Wood – a construction material  
for the 21st century.”*



[46]

## 1. Introduction

### 1.1 Why wood?

According to the dictionary the word **Trend** is *a general development or change in a situation or in the way that people are behaving*. Trends can be concerning, complex and from time to time even paradoxical but if we really understand them, they could guide us predict and even shape the future. During recent years terms such as ‘bio’, ‘eco’, ‘green’ and ‘sustainable’ are defined as ‘fair’ by the media and therefore products carrying the mentioned labels are becoming potential big sellers. As a result, the consumer is being driven by the so called neo-ecological mindset, which leads to new changes in almost every industry. The pursuit for sustainable, environmentally friendly and climate-neutral methods of constructing leads to an increasing acceptance of a material: wood, our only widely used building material that is truly renewably, and therefore also sustainable. In the following years, the wood industry will experience a real expansion, mainly driven by the affection of people eager to live a healthy and sustainable-eco lifestyle [1]. In addition, the agreement to reduce the worldwide carbon emissions in Paris 2015, would also affect the usage of wood in the building industry.

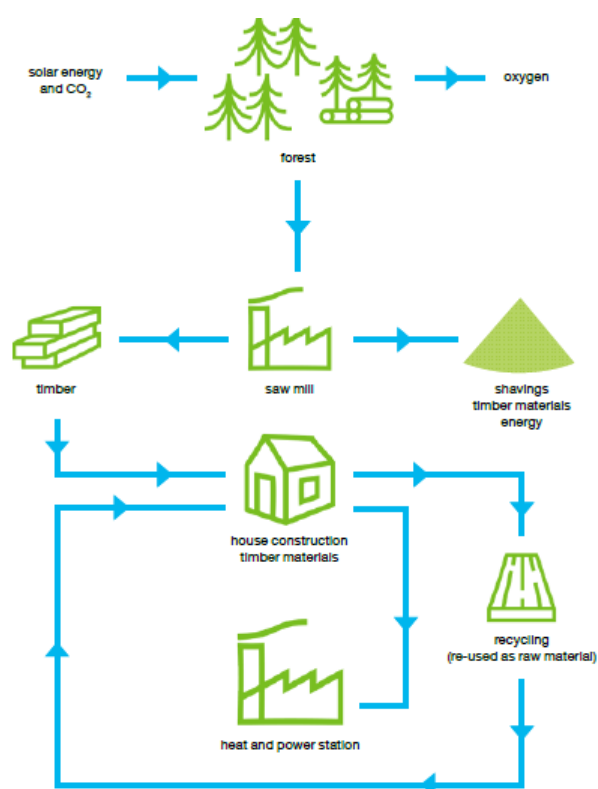

Figure 1 Wood as a reusable material [46]

It is not a secret that the construction industry is responsible for a vast portion of the total green house gas emissions globally. Between all, of the so called ‘traditional’ construction materials the leader by far is cement production, with approximately 8% of the global CO<sub>2</sub> emissions in 2015 and when one adds the rest of the materials and the construction process, we get a number not to be proud of [2]. In order to compare the environmental impact and sustainability of products made of various materials, we use the Life cycle assessment (LCA). It illustrates the cycle of a material over production, construction and usage right up to demolition and recycling

of the waste material. If we try to assess the sustainability of a building, various aspects should be considered. This include expenditures during the useful life - for example the heat energy required, up until demolition activities. Trying to add building products made from forest resources or wood in the analysis, will literally mean that the exchange of biogenic carbon between forest, soil and atmosphere is being adjusted into different phases. Namely the carbon stored in the products is a delayed biogenic emission or carbon sink, whereas reforestation continuous to absorb carbon from the atmosphere [3]. Therefore, it is clearly that the use of renewable energy sources and materials should be emphasized, which would theoretically make it possible for homes to become carbon neutral. In addition, the only building material that is carbon negative and is widely available is timber and the construction products made from it. In other words, the positive effect that timber has on the environment is called carbon sink, the primary chemical compound responsible for the greenhouse effect.

## *1.2 Sustainable buildings*

Apart from the enhanced greenhouse effect, responsible for the climate change, the population growth exerts urbanization, which is an issue that we should not neglect. According to the UN today, 54 per cent of the world's population lives in urban areas, a proportion that is expected to increase to 68 per cent by 2050 [53], which leads to constant pressure on building with increased densities or taller buildings. Sustainable urbanization is key to successful development, so one of the solutions to the problems we are dealing with are mid-rise timber buildings. So far timber has been related mainly to low-rise buildings, primarily due the main inhibitor, the outdated building regulations. On the other hand, the improvement of fire safety standards, connections and development of software analysis in timber engineering, has shown that timber can be even used for construction of high-rise buildings. With that in mind the creation and application of CLT and GLULAM offers a viable alternative to concrete and steel buildings in modern urban areas [2]. However, there should not be indifference towards the development of hybrid structures, where strengths of different materials are being combined together.

With the new chapter of mid and high-rise timber buildings there is a new concern regarding the use of mass timber and hybrid structures, which is construction moisture and its influence in short and long-term performance and durability of the mass timber product.

### *1.3 Aim*

The following study focuses on evaluating and minimizing the risks of construction moisture damage in different timber construction systems and engineered wood products, with an emphasize on plate shape mass timber products such as CLT. Primary aim is to evaluate the successful on-site moisture management by analyzing successful building projects from practice and their agenda to cope with construction moisture. Moreover, to assess if the amount of wetting mainly caused by rain during exposed construction could be harmful to the timber.

### *1.4 Objectives*

The aim is achieved and motivated by the following research:

- An in depth, investigation and general overview of timber construction types and mass timber moisture behaviour, with highlight on CLT as the riskiest type of product because of its plate geometry and location. The required literature survey forms an important basis for problem understanding and moisture management.
- Explanation of some moisture management principles and guidance, which are based on findings from the literature survey and carried interviews on a current ongoing project.

### *1.5 Method*

Firstly a vast literature survey is performed in order to establish critical timber construction types, material and moisture properties. Some of the founded data is discussed into details. Based on the research from practice projects and findings from: articles, books and papers the data is evaluated for further moisture safety criteria and moisture management for future projects. The study relies on 50-60 of the most relevant references, which were found on academic sites with research, articles and handbooks.

Furthermore, to some degree interviews have been used as a research method and valuable insights such as: moisture measuring techniques, sustainable building solutions and on-site protection have been gained by talking to employees from visiting a building site. Some of the gained photos and information from the building site is added in the study.

## 2. Theoretical framework

### 2.1 Chapter outline

In the following chapter, the theoretical background of moisture and wood would be discussed into details. Properties of wood and moisture transport methods with simple equations for the described processes would be also introduced.

### 2.2 Anatomy and wood properties

Wood is a natural and organic material with a complex biological structure, a formation of different cell types and many chemistries, which act together to satisfy the needs of a living plant. It is a complex chemical creation made of 50% carbon, 43% oxygen, 6% hydrogen and other compounds, which cluster and form macro molecules, in this case cellulose, hemicellulose and lignin. Timber material is built up by trees and the structure of the material can also be affected by the circumstances the tree is exposed to [7]. The material can be extracted from two types of plants; *softwoods* and *hardwoods*, the majority of construction wood including CLT and Glulam, in Europe being spruce and fir, two softwoods. There are couple of differences between softwoods or conifers and hardwoods or deciduous trees, which include: growth pattern, leaf shape and the structure of the wood itself [4]. A solid understanding in wood anatomy ensures insight to the realm of wood as an engineering material, in a way that guarantees optimal exploits of its mechanical and physical characteristics potential. This means examining wood on a macroscopic and microscopic level, including wood fibres and cells.

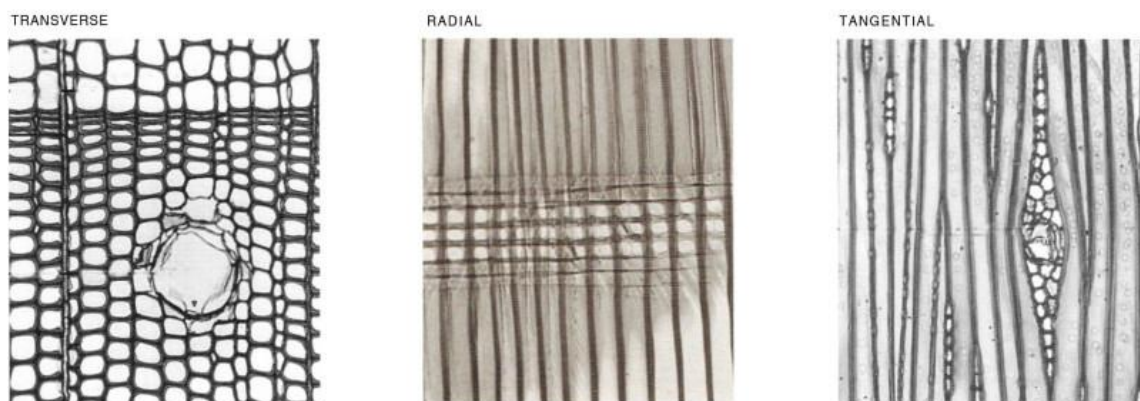

Figure 2 Microscopic cellular sections of pine wood [57]



### 2.2.1 Microscopic structure

#### Softwood

The wood structure of conifers comprises two cells; *tracheids* and *parenchyma*, most common cell type being tracheid, with almost 90% of the volume, often called fibre or grain and mainly oriented in the longitudinal direction of the tree. It is a tube-shaped cell with a size of 2-4 mm length and 0,1 mm width-diameter, which is bound to other cells with a middle layer acting as an adhesive, mainly consisting lignin. Tracheids are sometimes also referred as strength and water pathways of a tree. [7]

#### Hardwood

The structure of hardwood is more complicated and includes more types of cells, it has evolved to a higher level than softwood, and cells here have more specialized function [7], thereby it is not that important to be discussed into biological details.

All wood cells have small openings – *pits*, these allow transport of mineral and nutrition within the tree. Pits are especially important during wood drying or impregnation, since closure its irreversible, thus leading to poor moisture permeability.

### 2.2.2 Macroscopic structure

The external portion of the trunk or stem is known as *sapwood*. It is characterized by the presence of living wood cells responsible for storage of substances, which protect the tree from biological attacks. The wood in the inner area is called *heartwood*, with no living cells its solely function is stabilizing and strengthening the tree. Heartwood is formed by a biochemical process called heartwood formation, which transforms sapwood. The true center of the tree is called *pith*.

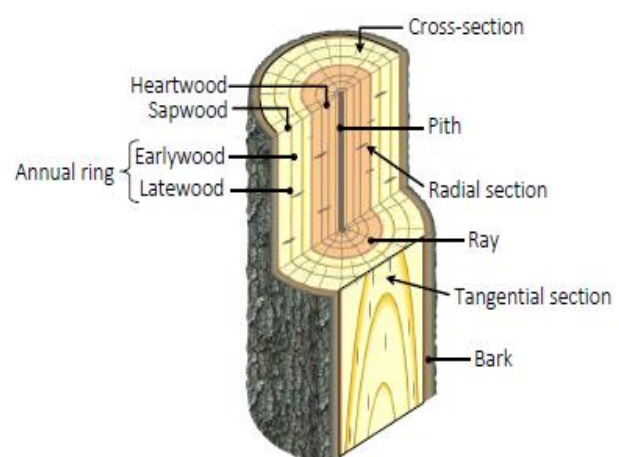

Figure 3 Macroscopic structure and sections of wood [7]



### 2.2.3 Wood properties

Properties of wood such as *density*, *hardness* and *bending strength*, are directly derived from the interrelationship of the cells that constitute the wood make-up. Such larger-scale properties are based on chemical and anatomical details of the wood [7]. Wood is defined as an *anisotropic* material, mainly because of the variation in cell size and partly due to the direction of specific cell types. Properties of wood are defined in three main orientations (*Figure 3*); *longitudinal/sectional (X)*, *radial (Z)*, and *transverse orientations (Y)* [4]. It can be easily understood that strength is directly correlated to orientation, with compression strength being higher parallel to the fibres than perpendicular. The same applies for all modulus, thus making the loading direction extremely important. On the other hand, moisture is opposite from stress resistance, with resistance in the tangential direction being more effective than in radial direction and longitudinal resistance being the weakest, mainly because of tracheids orientation.

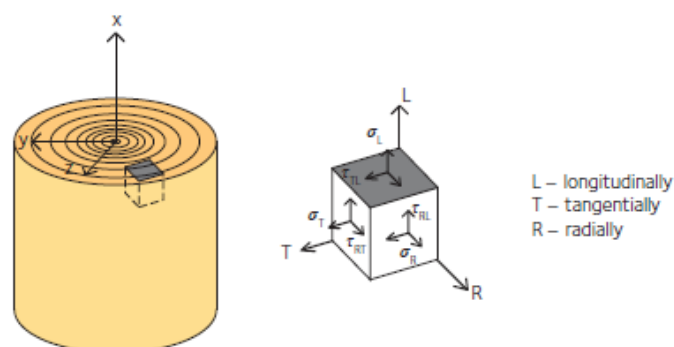

Figure 4 The main anisotropic directions: longitudinal, tangential and radial [4]

*Density* is a physical wood property that is moisture dependent, wood mass and volume are related with moisture content. It is defined as:

$$\rho = \frac{m \text{ [kg]}}{V \text{ [m}^3\text{]}} \quad (2.1)$$

All standards define density in terms of moisture content, usually it is based on mass and volume at 12% MC. Normal density for softwood varies between 300 and 600 kg/m<sup>3</sup> [4].

## 2.3 Moisture and physical properties of wood

### 2.3.1 General

Moisture-related properties of wood are critically important for understanding and predicting the response of engineered wood products building assemblies, which are exposed to the environment while constructing. Understanding those properties is essential for future designing by avoiding problems such as mold growth, decay and dimensional changes. As a hygroscopic material, wood moisture content is always related with the relative humidity of its surrounding air. Additionally, mainly because of its' structural arrangement and organic origin all wood properties are linked with moisture content, especially when moisture content is below the *fiber saturation point*. It could not be argued that with moisture increase;

- *Stiffness and strength decrease,*
- *Creep deformation increases,*
- *Thermal conductivity rises,*
- *Appearance of fungal infections, when MC exceeds 20%.*

Moistures impact on wood properties is presented in Table (2-1) [10].

<i>Property</i>	<i>Variation</i>
<i>Compressive strength parallel to the grain</i>	<i>6%</i>
<i>Compressive strength perpendicular to the grain</i>	<i>5%</i>
<i>Bending strength</i>	<i>4%</i>
<i>Tensile strength parallel to the grain</i>	<i>2.5%</i>
<i>Tensile strength perpendicular to the grain</i>	<i>2%</i>
<i>Shear</i>	<i>2.5%</i>
<i>Modulus of elasticity (MOE) parallel to the grain</i>	<i>1.5%</i>

*Table 2- 1 Properties variations caused by change of MC for 1% [10]*

### 2.3.2 Fiber saturation point - FSP

When water penetrates, into a dried wood interior, molecules firstly reach the surface of the cell walls or the hydroxyl groups, which force the cellulose chains to far apart. The result is both declined force of attraction and weakened cell wall hydrogen bonds. Finally, when the cell walls are packed with water, molecules start to fill the cell cavity. The point where mechanical properties are no longer affected by the changes in MC is called *fiber saturation point* or *FSP*. Physically it is defined as the MC at which the cell wall is filled with water-molecules but the cell cavities are still empty or as the point at which free water starts to

accumulate [10]. To simplify water in cavities do not influence on physical and mechanical properties of wood. For European softwoods, the FSP is within 27% and 33% [4]. For engineers, knowing the FSP is an important aspect, considering the fact, that most significant changes to physical and mechanical properties occur before it is reached.

### 2.3.3 Moisture content - MC

Water content in wood is defined with two terms; *bound water* and *free water*. The term used for water content up to FSP is bound water. It is stored in cellulose hydroxyl groups with hydrogen bonds in the cell walls and Van der Waals forces. The remaining water found in the cell, which has no molecular bond to the wood is defined as free water [10].

As previously mentioned, the amount of water found in wood is moisture content or moisture ratio, defined as the weight of the water in damp material divided by the weight of the dry material, meaning moisture content exceeding 100% is also possible. It is often given in % by weight [4];

$$u = \frac{m_u - m_{dry}}{m_{dry}} \cdot 100 \quad (2.2)$$

$u$  – moisture content [%]

$m_u$  – mass of wet sample [kg]

$m_{dry}$  – mass of wood after drying at 103C° for 24h [kg]

### 2.3.4 Equilibrium moisture content - EMC

Wood as a hygroscopic material exchanges moisture under ambient conditions with the surrounding environment. Considering that wood is mostly protected from liquid water and solar radiation, the amount of moisture gain or loss predominantly depends on the relative humidity of the air and the temperature [10]. In the process, the loss of moisture is referred as *desorption* and gain in moisture as *absorption*. The combination of temperature and humidity of the surrounding air corresponds to a specific moisture content level, where the wood neither gains nor loses moisture. This moisture content is known as the *equilibrium moisture content* or *EMC* [4]. As a variable, EMC is different for various wood species, nevertheless it is a key parameter for engineers in the calculation of relative moisture content of the wood elements when assembling. Taking this into account engineers reduce the risk of moisture difference that

can cause not only problems appearing in connections, such as swelling and shrinking but also vulnerability to pests, thus decreasing durability.

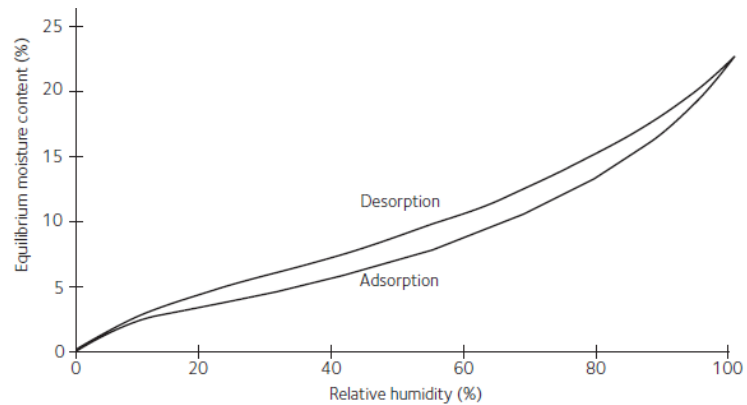

Figure 5 The relationship between relative humidity and the equilibrium moisture content [4]

### 2.3.5 Durability and Biodeterioration

Considering durability and biodeterioration, *decay* is the main process in which biological agents cause degradation of organic materials. Reasons to control agents range from priorities such as minimizing structural damage, to protecting indoor air quality and even for aesthetic reasons. Primarily responsible for the process are *fungi*, which can form *mould* spores that feed sugars stored within the wood cells. On the other hand, *rots* are more problematic considering the fact, that they break the cellulose and lignin in the cell walls, thus affecting the structural capacity [13].

### 2.3.6 Dimensional changes

Wood shrinks when it loses moisture and swells when it gains, primarily at MC below the fiber saturation point. The process of dimensional change of wood can be described on a microscopic level as a process in which; with the moisture change, microfibrils shrink and swell. Water molecules in every cell wall are bonded to the surface of the micro fibrils, which initiates dimensional changes in the wood. Shrinkage and swelling are defined by various parameters, which include not only anatomical structure but also wood density and lignin proportion. As lignin opposes water much more than cellulose, lignified wood species are less prone to dimensional changes when compared to less lignified. Microfibrils and their orientation are also responsible for the direction and degree of the dimensional change, longitudinal or transverse [10]. For European wood species quiet common value for longitudinal swelling is 0.4%, for radial swelling 4.3% and for tangential swelling 8.3%. Differences can be explained by the wood structure in various directions, nevertheless the swelling or shrinking in longitudinal direction might be small but for large lengths it is still necessary to take it into account [10].

## 2.4 Moisture physics

### 2.4.1 General

This subchapter discusses physical properties of water, the moisture storage phenomena and transport, which occurs in engineered timber.

### 2.4.2 States of moisture

Water as a molecule is composed of one oxygen atom ( $O$ ) and two hydrogen ( $H$ ) atoms, giving the commonly known identity of  $H_2O$ . It can be found in four common states: gas, liquid, solid, and adsorbed, each state having its own characteristics and properties. For timber construction the primary concerns are gaseous, liquid, and adsorbed, with ice being an insignificant issue. It should be also said that under most circumstances, absorbed water will likely desorb into gaseous water.

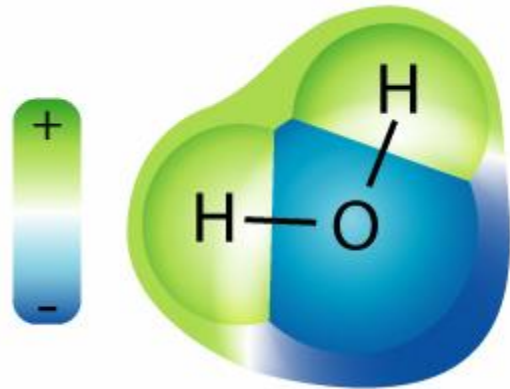

Figure 6 The water molecule [54]

### 2.4.3 Moisture in air

The amount of water vapour, which can be accumulated in a unit volume of air, is possible to be described as a sponge that can soak up water as well as other gasses. Because there is a direct relationship between moisture content, temperature, and relative humidity and their effects on the moisture characteristics of hygroscopic

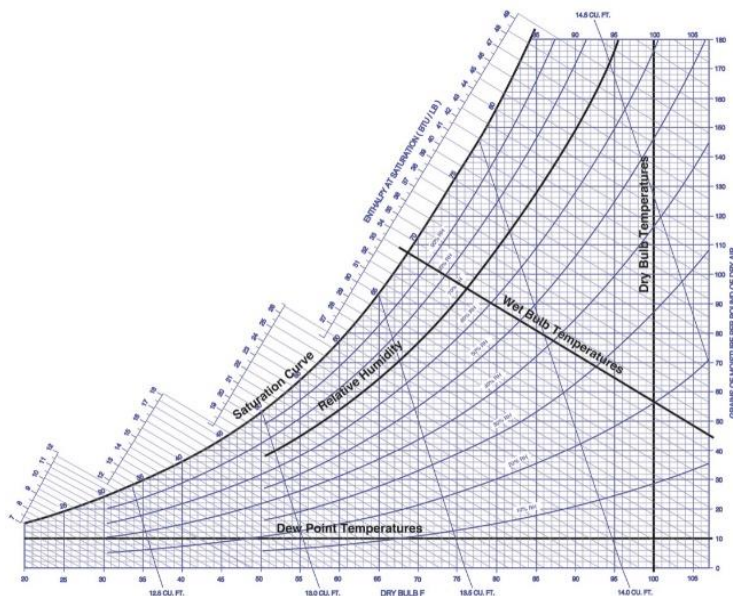

Figure 7 The Psychrometric chart [55]

materials, the sponge gets bigger and stores more water with increased temperature. Nevertheless, the sponge can absorb a given amount of water before it's saturation point, also known as the *saturated vapour pressure*. The study, which is required to understand these relationships and gas mixtures is known as *Psychrometrics* [13]. In most cases the *psychrometric chart* is used to graphically describe the relationships (Figure 7). The graph

plots vapour pressure along the vertical axis and temperature on the horizontal axis, with saturated vapour pressure line bounding the upper limit of saturated water vapour in air.

*Relative humidity (RH)* is the relationship between vapour concentration in a cubic meter of air and the value of the saturated vapour concentration in a cubic meter of air at a given temperature [18].

RH of 100% equals condensation.

$$RH = \frac{V}{V_{s(T)}} \quad (2.3)$$

*RH relative humidity [-]*

*V vapour concentration [g/m<sup>3</sup>]*

*V<sub>s</sub> saturated vapour concentration [g/m<sup>3</sup>]*

or else, the relationship between the quantity of vapour pressure and the saturated vapour pressure at a given temperature [13];

$$RH = \frac{p_w}{p_{ws}} \quad (2.4)$$

*RH relative humidity [-]*

*p<sub>w</sub> vapour pressure [Pa]*

*p<sub>ws</sub> saturated vapour pressure [Pa]*

#### **2.4.4 Moisture storage in materials**

The amount of water that a material can store mainly depends on its porosity, specific surface area and its hygroscopicity. Moisture binds in the material's inner pores, both vapour and in liquid form, how much depends on the porosity. At the end, the material eventually reaches equilibrium with the relative humidity of the surrounding air. This is mainly because of the moisture's diffusion, from the air into the pores [13]. Water in materials can be stored in five different ways or methods, as it is shown in Table 2-2;

<i>Moisture Form</i>	<i>Storage Location</i>
<i>Free water vapour</i>	<i>In pore volume (porosity)</i>
<i>Adsorbed water vapour</i>	<i>On pore walls (specific area)</i>
<i>Capillary condensed water</i>	<i>Held in very small pores</i>
<i>Capillary bound liquid water</i>	<i>Surface tension in pores</i>
<i>Unbound liquid water</i>	<i>Within pores of material</i>

Table 2- 2 Moisture storage in materials [55]

The relationship between the specific material moisture and the relative humidity of the surrounding air is in most cases described with a *sorption isotherm curve* [10]. The various storage states are shown on the Sorption Isotherm (*Figure 8*).

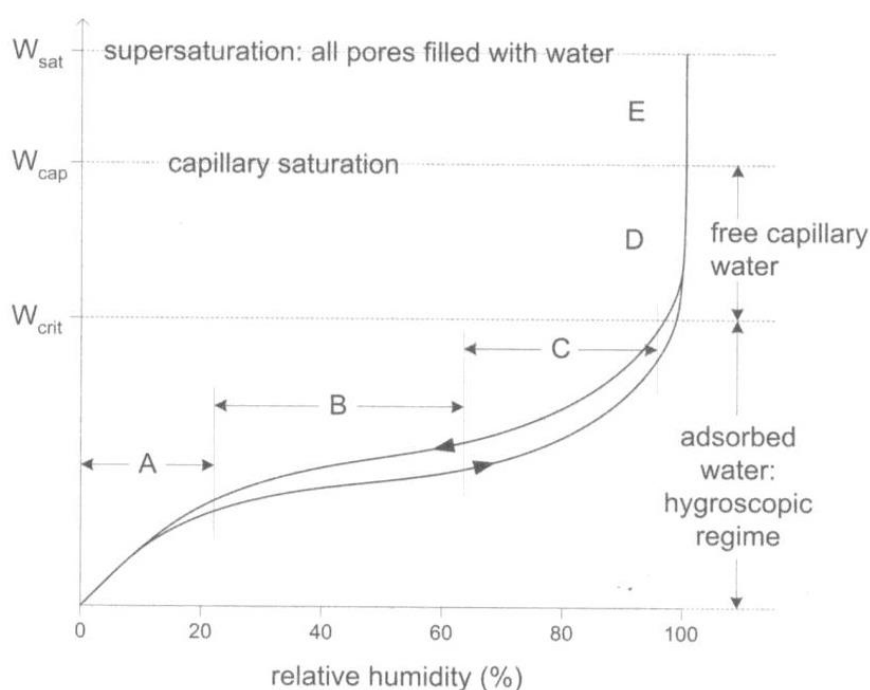

Figure 8 The Sorption Isotherm [55]

As it is described area **A** marks a single layer of water molecules absorbed to the surface, **B** indicates multiple layer of water molecules on the surface walls. Area **A** and **B** are also known as hygroscopic range. Range **C** is when capillary condensation occurs, and **D** indicates capillary suction as a main storage mechanism for the free water. Because wood is a capillary active material, it has the potential to take up water in capillaries and continue with the process until it reaches the saturation point. The capillary saturation point or range **E** is where most water is within the pores of the material, but this does not mean that all pores are filled with water. Filling all the pores or reaching maximum water content is a process that requires great pressure differences and it is almost impossible to happen naturally [13].



### *2.4.5 Moisture transport through porous materials*

The flow of moisture through porous materials or more layers is a process of great complexity, which includes a vast portion of equations and it is not completely understood. This subchapter would only introduce the basic principles and try to present a simplification of the complex process.

The driving force behind moisture flow in porous media includes; temperature, relative humidity, water vapour pressure, water vapour density, liquid capillary pressure, moisture content, and chemical potential. From all of the mentioned variables, only three are independent, and if air pressure is considered as a constant, there are only two remaining; temperature and water vapour, or temperature and relative humidity. The contribution to moisture flow from the variables is not equal, neither is the variation linear and the complexity of anisotropy in the materials' porous system should be also considered. Consequently, this is the issue that makes the process so complicated [13].

It could not be argued that there are five mechanisms, which contribute to moisture flow in porous materials (*Table 2-3*). The total moisture flow is mainly dominated by diffusion, surface diffusion and capillary transport, although different kind of mechanisms are active during different relative humidity [18]. In engineering the transport mechanisms are mainly diffusion and capillary transport, nevertheless surface diffusion also participates from a macroscopic perspective. A preview and a simplified version of the transport phenomenon, their driving potential, and the water phase may be found in the table below.

<i>Mechanism</i>	<i>Water Phase</i>	<i>Driving Potential</i>
<i>Diffusion</i>	<i>Gaseous</i>	<i>Water Vapour Concentration</i>
<i>Effusion</i>	<i>Gaseous</i>	<i>Water Vapour Concentration</i>
<i>Surface Diffusion</i>	<i>Adsorbed</i>	<i>Relative Humidity</i>
<i>Capillary Transport</i>	<i>Liquid</i>	<i>Capillary Suction Pressure</i>
<i>Osmosis</i>	<i>Liquid</i>	<i>Solute concentration</i>

*Table 2- 3 Moisture transport through porous materials [55]*



## 3. Timber construction and engineered wood products

### 3.1 Chapter outline

In modern construction timber buildings systems are used to construct a wide variety of buildings from single-family homes to multi-storey and long-span buildings, which present a bigger test not only for the material but also the contractor.

Timber building systems are more common to be found in Nordic countries and central Europe: Germany, Austria, Switzerland and to some degree in Italy and Slovenia. The great ductility also ensures a fair earthquake performance, which makes them to be well established in Japan and New Zealand. A list of other countries that use timber mostly for housing and is increasingly present, includes USA, Canada and Australia.

As all construction projects are complex activities, they pose various technical risks. The first association when one mentions' timber construction and products risks, without any doubt is fire-resistance, no matter the fact that the majority of the engineered wood products have a high fire rating. On the other hand, water damage is rarely mentioned by the public, regardless of the products' ability to hide construction moisture for years, resulting in damage to the bearing elements and a potential incapability to withstand future loads. Taking this into account one should not disrespect the impact, which moisture or environmental exposure has on wood while longer construction time, as in multi-storey timber buildings. To be more precise, the interest of this chapter is to introduce and analyse moisture's influence in different construction types and materials so future building aspects could be provided for different scenarios.

### 3.2 Building systems

Throughout history different building systems have been developed in various countries, they can be divided into three main categories [11]:

- *Panel systems*
- *Modular systems*
- *Post and beam systems*

### 3.2.1 Panel system

Panel systems apply *light frames* or *solid wood elements* as their main technology.

*The light frame system* was introduced in USA in the 1830's, it consists of joists and studs placed at even distances and insulation in-between. Sheathing was used to stabilize the elements. In USA light frame systems are built on site, whereas in the Nordic countries they are mostly prefabricated, considering construction moisture and exposure. One of the problems with light frame systems are shorter spans. However, with the introduction of mass timber products, joist and studs can be replaced with more durable elements, hence longer spans are possible. Another issue, not to be forgotten in the design process mainly because of their lack of mass, is acoustics [11]. For moisture management of framed systems, it is important to allow shrinkage and swelling by allowing appropriate joints between e.g. facade and material.

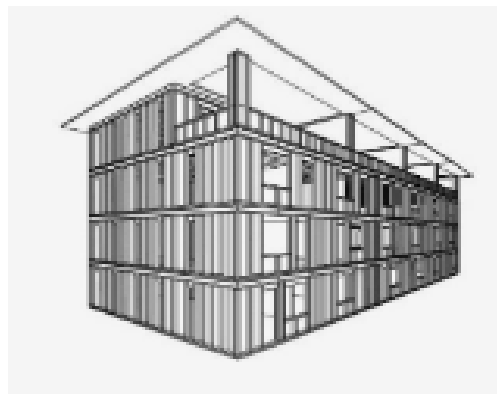

Figure 9 The light frame construction system [36]

*Solid wood system* structures are divided into two subcategories: walls made of *solid wood beams* or *Log houses* and *planar cross laminated elements* or *X-Lam* (cross -laminated timber). The construction process is mostly prefabricated, where CLT elements are delivered to the site and later-on assembled. Solid wood elements or CLT are particularly used in Germany, Austria and Switzerland with an emerging market in rest of Europe [11]. The walls are usually

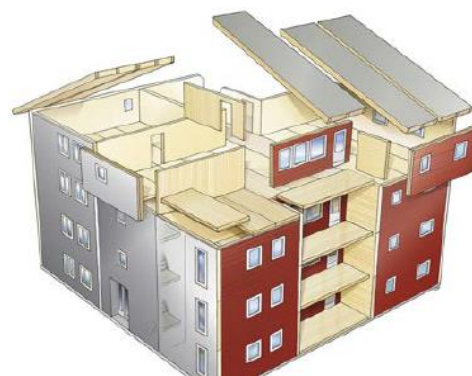

Figure 10 Solid X-Lam elements multi-storey construction system [11]

additionally insulated but it is also possible air to be enclosed inside of the elements, thus significantly improving their insulation properties. Solid wood panels or wooden beams and panels are also used as a main floor construction [36]. Wetting and construction moisture is not a primary concern for single houses but today the main research and development of solid wood systems aims towards multi-storey buildings, which tend to be more brittle towards exposure during construction.

### 3.2.2 Modular system

**Modular systems** utilize *light frames* or *solid wood elements* as their primary building technology.

*The light frame modular system* combines the idea of prefabrication and factory assemblance in which every volumetric box consists of walls, floor, ceiling and all secondary services. The same principles as in light frame system single-family house applies, when constructing the volumetric box. Furthermore, it is essential for modules to be weather protected while transport and assembly. Because of the compatibility of the modules, which can be composed of one room or even the whole apartment, the system can be adopted for building: student housing, hotels and housing for the elderly [11]. Potential problems facing this kind of construction surely are dimensions of the modules, which are limited by the manufacturer and transport possibilities, while construction moisture and exposure are minor issues.

*CLT modular systems*, consist of prefabricated modules completely made of CLT panels, which are later transported to the building site. The use of CLT instead of light frame, makes it possible for modules to be stiffer and stronger. Regarding exposure and moisture, it is essential modules to be protected while transport and assembly [11]. The *Treet* project in Bergen is an example of a successful usage of building modules, where all the necessary protection measures were carried out [29]. The measures and the project would be discussed later in the study.



Figure 11 CLT modular system [11]

### 3.2.3 Post and beam systems

The supporting structure is composed of *posts* and *beams* placed at a wider distance or as it is known - a *big frame structure*, thereby mostly utilized for industrial, commercial buildings and sport arenas. Because of the broader distance between the load bearing elements, more options when designing the space are available. In most cases the load carrying structure is visible, thus the combination of timber



Figure 12 Post and beam- Skelet system [36]

structure with glass curtain walls. The grid-based system in which the forces are solely transmitted through the beams and columns is stabilized mostly with diagonal bracings or shear CLT walls [29]. It could not be argued that a new era of post and beam structures has begun with the development of mass timber products such as: Glulam, CLT and LVL. Reference projects, that would be discussed in the study includes *Mjøstårnet* and *Skipet*.

Post and beam structures can be divided into two main subcategories: *Short-span structures* and *Long-span structures*, each one of them consists of various structural designs and different types of buildings fall within a certain category [11].

### *3.3 Engineered wood products and mass timber*

#### *3.3.1 General*

As the timber industry evolved through time, the size of the structural timber or sawn timber that could be found only up to certain dimensions was no longer directly associated with the dimensions of the growing tree in the forest. With time, new challenges appeared for the traditional sawn timber - made of wood in its natural structural form, in particularly related to the non-homogenous wood structure. Essentially, wood as a natural material tends to differ with its' properties in various directions mainly because of its' growth process, hence the primary concept underpinning the development of wood-based products [15]. However, the significant differences in strength, stiffness properties and moisture behavior in various directions no longer affects to the same degree mass engineered timber products. Mass timber or engineered timber adopts the advantages of solid timber, thereby improving its' structural integrity. As such, it can be applied in various types of buildings, only by a simple on-site assembly. Moreover, it can be made into specific shapes and technical standards, from beams and columns to load bearing panels. Therefore, making the idea of a new kind timber building possible.

In order to understand timber building systems and their behavior with construction moisture it is essential to briefly introduce the products in the family of engineered timber. From the gathered information, a brief conclusion for the mostly used and fragile products to exposure and moisture in modern multi-storey timber buildings is made. However, the emphasize should be on CLT and Glulam, as a result of their wide acceptance as main bearing elements in recent projects.

### 3.3.2 Wood products based on sawn timber boards

#### **Glued Laminated Timber (Glulam):**

The first patent for engineered wood products-lamination process for sawn timber boards where the grain of all laminations runs parallel with the length of the member or is aligned in one direction, was proposed by Otto Hetzer in 1906 [16]. Today, simply known as glued laminated timber or Glulam, it consists of several lamellae with aligned fibre direction, previously selected and positioned based on their properties and later glued over their surface with moisture resistant adhesives, resulting in rigid connections. This makes glulam much more suitable for linear building elements such as columns and beams, which if combined form framed systems [15]. While it might seem that glulam beams are much stronger than solid beams of the same size, test have shown that there is a slight difference when it comes to maximum strength, the real advantage is the significantly lower variability of strength.



*Figure 13 Glued Laminated timber elements [16]*

Concerning Glulam beams, shear failure should not be neglected but tensile failure parallel to the grain of outer lamination should be emphasized as their weakest link, generally emerging in a knot or a finger-joint [16]. While typically used as beams and columns, glulam can be also used in the plank orientation for floor or roof decking, whereas glulam ‘panels’ can be used to create complex shapes and uncommon geometry. When exposed to wetting the most critical areas of a linear glulam element are edges or end-grains, due to the fiber direction and moisture transport. In order to protect it from on-site wetting and moisture, ends should be fully covered while exposed construction.

The production process of glulam components is entirely automated (Figure 14) and efficiently calculated, it comprises the following steps [16]:

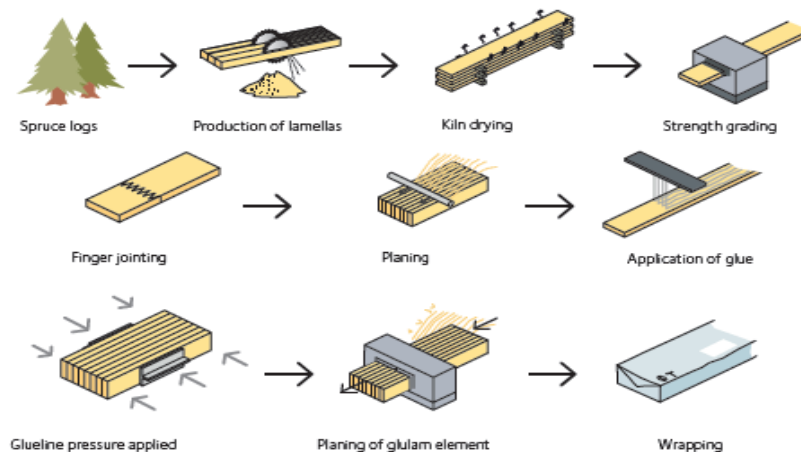

Figure 14 Glulam production process scheme [15]

- Pre-grading of the boards, sawing timber from sustainable managed forests.
- Drying of the boards, moisture content between 6-15% and all laminations have less than 5% difference in moisture content.
- Strength-grading of the boards.
- Finger jointing lamellae.
- Capping of the continuous lamellae to the required length.
- Planing the lamellae.
- Applying adhesive, most commonly Melamine-Urea-Formaldehyde (MUF) or Urea formaldehyde resin (UF).
- Inserting into a pressing jig and pressing, curved products are usually made with thinner laminations and adapted to specific shapes before curing of the adhesive.
- Planing to the final member size.
- Transport of wrapped flat-packed components.

The production process is regularly checked for the strength of the finger-joints and delamination test of the adhesive according to EN 14080 (*Glued laminated timber and glued solid timber – Requirements* [16]), which includes details of both production requirements and strength classes.

### Cross Laminated Timber (CLT):

CLT, sometimes referred as X-LAM is an innovative wood product firstly introduced in the 1990s in Austria and Germany and since then constantly gaining on popularity in various types of applications [15]. The experience shows that CLT construction can be competitive, particularly in mid-rise and high-rise buildings. Main advantages of this plate shaped product to solid timber, are the approximated in-plane isotropy and significantly lower properties variations [16]. As a product, it comprises layers of dimension lumber oriented perpendicularly



to one another and glued with structural adhesives to form panels, which are later classed as structural wood materials. CLT can be produced in various dimension, mainly defined by the manufacturer and later adapted to suit floors, walls and roofs. The process of production, design, application and construction will be later on discussed into details, considering the fact that the carried literature survey and reference building projects revealed it as the mostly used and fragile component for wetting and moisture in modern multi-storey timber buildings, mainly because of the area it covers and its exposed horizontal location.

### **Dowel Laminated Timber (DLT):**

Dowel-Lam or DLT - Dübelholz as known in Europe, was developed in the 1990s by Tschopp Holzbau as the first no glue and nails engineered timber product or as a 100% wood product. It is made from softwood lumber boards (2-by-4, 2-by-6, etc.) stacked together with dowels, in many ways comparable to Nail Laminated Timber (NLT), yet superior in every way. All DLT panels are finger-jointed, creating a stiffer and stronger panel compared to NLT, thus eliminating the butt-joints characteristic of NLT. The production process includes fully automated machinery, which makes it often the cheapest timber product on the market. Leading manufacturers are mainly located in German speaking areas of Europe [9]. Because of its' main advantage – the ease to apply acoustic strips and thus achieving acoustic objectives, the panel can be used for floor, wall, and roof structures, while keeping the wood indoor fully exposed. Other application might include diaphragm and shear walls, bearing walls with covered or exposed DLT and two-way spans only by using screw reinforcement inside the DLT panel [16]. As it supports the trends towards prefabrication and sustainability as the future of construction, it has a gaining potential to develop a larger market share and along with it a further product innovation is probable. In the carried survey, reference projects and broader use in practice could not be found, so as, to evaluate how the product behaves when exposed to wetting on a construction site. Considering its similarities to glulam the behavior however is not expected to be that different, therefore wetting and fiber orientation should be considered.



*Figure 15 Dowel laminated timber element [9]*

### 3.3.3 Wood products based on veneers

#### Laminated Veneer Lumber (LVL):

Laminated veneer lumber is an engineered product made from the outer wood layer. For this reason, logs are rotary cut and peeled in order to produce the thin (2–4mm) layers of wood, called veneers. The production process involves: drying to a specific moisture content 12-15%, strength grading and using an adhesive to form structural panels and elements with maximum size 3000 X 24000mm [15]. Veneers fibre direction is mostly parallel to the longitudinal direction of the LVL element, yet in some cases to achieve higher panel stiffness, some layers have grain direction perpendicular to the main fibre direction. Overall, LVL has high bending,



Figure 16 Laminated veneer lumber elements [61]

tension and compression strength, as well as high shear strength and a relatively high modulus of elasticity, which makes it a suitable alternative to glulam for linear load bearing elements and in addition, when the grain direction is perpendicular, usable for floor structures [16]. However, referring to the *Mjøstårnet project*, when the product is exposed to wetting in practice, it tends to soak-up water along the edges. Application and use of LVL is regulated in product standards EN 14279 and EN 14374 [16].

#### Plywood:

As one of the first timber products introduced on the market, plywood manufacturing process is almost the same as LVL, the only difference being the alternative crosswise layers or perpendicular veneers in order to ensure dimensional stability. It contains an odd number of bonded layers, three being the minimum. The odd number ensures that the outer thin sheets of wood (0.5 – 0.6mm) or layers are constantly oriented in the long direction of the panel, whereas the central plies may contain veneers (plywood), block-board or laminboard. Additionally, the type of veneer wood and adhesives used should not be neglected because they define the main plywood properties [16]. As it is mostly used as a sheathing material in horizontal (floors, roofs) or vertical (shear walls) diaphragms, structural plywood is normally produced in sheets 1200 X 2400 mm or 1220 X 2440 mm with 12-24mm thickness. The stiffness of a plywood panel is primarily dictated by layers with grains running the same as the stress direction, mainly





Figure 17 Production method of veneer products [16]

because the modulus of elasticity perpendicular to the grain is only a fraction compared to its value in grain direction [15]. The moisture content of plywood is between 5% to 15%, nevertheless it should be said that it will not remain the same. Depending on the climate and the exposure it is expected to increase and achieve equilibrium with the surrounding area. Having said this, all of the standardized on-site protection methods for sawn timber should be considered. Plywood products are regulated in EN 13986 and in the EN 636 product standard [16].

### 3.3.4 Wood products based on strands, chips or fibre

#### Laminated Strand Lumber (LSL):

LSL or Intra-lam as it is known in Germany, is a product made of smaller poplar wood elements or strands, which are glued together with water resistant adhesive to form pieces of varying thicknesses and lengths mainly depending on the manufacturer. Most often dimension is approximately 0.8



Figure 18 Laminated strand lumber [16]

mm x 25 mm x 300mm. Because of the processing technique, the product tends to have higher density in the surface and a slightly lower density in the middle. The strength of the product is usually associated by the type of adhesive that is added. Depending on the strand alignment, two types of LSL could be defined: boards with strands in the direction of major axis and panels or boards with crosswise strand orientation. The first are suitable for linear bearing elements (beams, columns etc.) and the second for floors, walls and ceilings [16].

#### Oriented Strand Board (OSB):

OSB products are based on smaller wood elements or thin wood strands, which are later glued together with adhesives in an industrialised processes to form panels of different formats - with width up to 3 m, length up to 25 m and thickness up to 75 mm. Usually the production ratio varies approximately 95 percent wood and 5 percent adhesive. In order to achieve better characteristics of the product, outer layer strands are oriented parallel to the long direction, whereas inner layers are oriented randomly. Most common use includes as sheathing material for walls and floor structures [15]. Other products in the family, produced in similar way, worth mentioning are chip, particle or fibre boards. The wetting and exposure protection measures for products based on strands, chips or fibre includes basic methods from sealing to ventilation.

## 4. CLT as a building material

### 4.1 Chapter outline

As previously mentioned, an in depth understanding of CLT production, design, performance and construction process is essential in order to better determine its' behavior and response to wetting and construction moisture, consequently reaching smart solutions for proper on-site protection.

### 4.2 Market and manufacturers

As an innovative renewable plate-shaped product, with a potential to cut down construction schedules with prefabrication by 50%, is a recent history success story. Well established markets in central and northern Europe have tripled the market volume from 2008 to 2015, reaching the margin of 600,000 cubic meters [35]. Additionally, new big markets are emerging in North America, Australia and Japan. In recent years it is expected that the established markets will follow the multi-storey building concept, particularly 3 to 6-storey buildings, which would be responsible for the continuous product development [1].

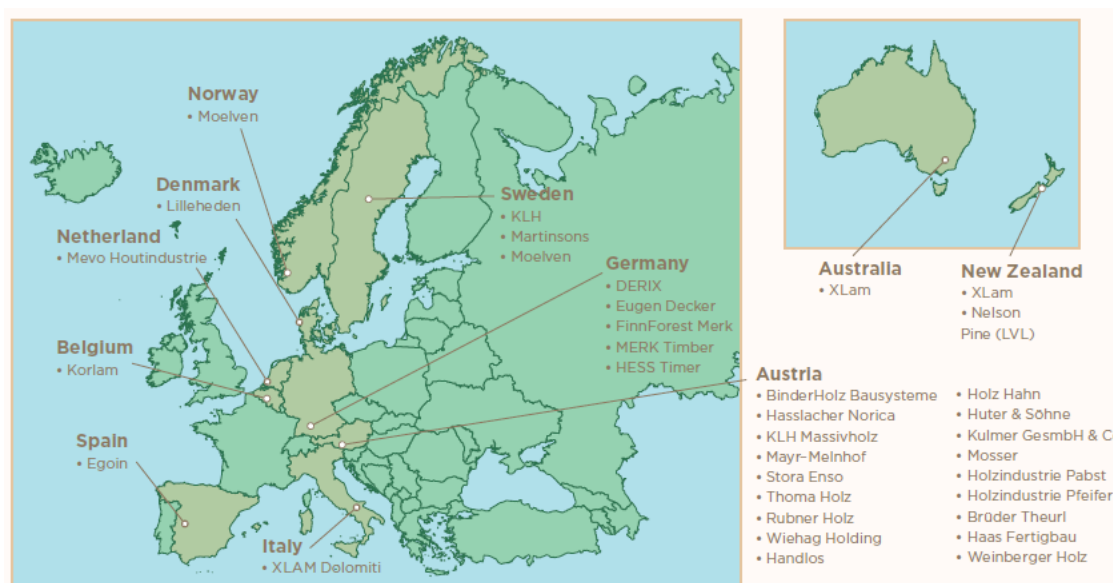

Figure 19 CLT leading manufacturers [6]

### 4.3 Manufacturing and composition

The design of a CLT panel has two different considerations; the loading resistance is considered in choosing the length and the structural thickness of the CLT panel, whereas the architectural features and protection features are considered for the non-structural outer layers.

Panels are manufactured in three or more layers of same or different lumber thickness or to simplify boards in a 90° crisscross pattern. With the crosswise arrangement dimensional stability and two-way bearing capabilities of the product are achieved. In order to meet certain specification two adjacent layers can be aligned in the same direction and in addition different strength classes can be applied in the same heterogeneous panel. Predominantly the product is made of soft types of wood, although local types with poorer properties can also be used. Most common species for CLT panels production includes Spruce and Douglas Fir, nevertheless, it is also possible to use Larch and Pine [8].

The production process of CLT panels involves several stages, from visual inspection to on-site delivery to the CLT assembler. Schematically the typical manufacturing procedure (*Figure 20*) can be divided into two basic steps [20]:

#### *1.1 Preparation and treatment of material*

#### *1.2 Arranging and gluing of material*

### *4.3.1 Preparation and treatment of material*

The boards are kiln or air dried to a moisture content (MC) tolerance of  $12 \pm 2$  %, followed by either visual or machine classification of material according to EN14081-1. In order to satisfy the required length or width of the panel additional planing, cutting and longitudinal joining using finger joints is required. Homogenous CLT products are generally made of timber class C24 compliant with EN 338, on the other hand, lower grade C16/18 class is allowed for combined sections in vertical layers [20]. It is widely approved to use adhesives with corresponding properties to those of the fundamental material. Most commonly used adhesives include melamine urea- formaldehyde (*MUF*), single-component polyurethane adhesive (*IK-PUR*), and emulsion polymer isocyanate adhesive (*EPI*), however, most of the manufacturers use the one-component polyurethane adhesive *Purbond*, which accounts for less than 1% of the total mass of the CLT panel structure [26]. The last stage of the first step is using finger joints according to specifications to connect lamellae longitudinally in order to obtain dimensions needed for fabrication of CLT elements.

### *4.3.2 Arranging and gluing of material*

The second step of the process is mainly focused on gluing and arranging of the final CLT product. Value range, of the applied pressure for boards gluing in the process primarily depends on the jacks that are used; for hydraulic from 0.10 to 1.0 N/mm<sup>2</sup> and 0.05 to 0.10 N/mm<sup>2</sup> for vacuum jacks [20]. Regardless of the unified process, a uniform compression value has not

been defined in the corresponding regulations. Glue types are mostly similar to those used for finger joints. In order to consider the aesthetic and building physics requirements (fire resistance, moisture, airtightness and sound insulation) a 6mm maximum spacing between lamellae is specified in many technical regulations, including EN 16351 [20]. Constant efforts are made by the manufacturers to minimize the spacing, some of them even produce individual CLT panel layers by gluing narrow edges of lamellae, and then the already formed layers are glued together along the wide sides to form the final product. On the other hand, it is suggested that glue along narrow sides of lamellae should be restricted only to inner layers, mainly because of crack appearance as a result of timber properties such as shrinkage and swelling, caused by change in temperature and moisture. After the glue has cured, the product is sanded and cut into final dimensions. Computer numeric control (CNC) plasma cutting or blade cutting is used for corrections adjusted to the customers' requirements. The final product is at last additionally protected against outside weather and exposure and it is ready for transport and assembling [8].

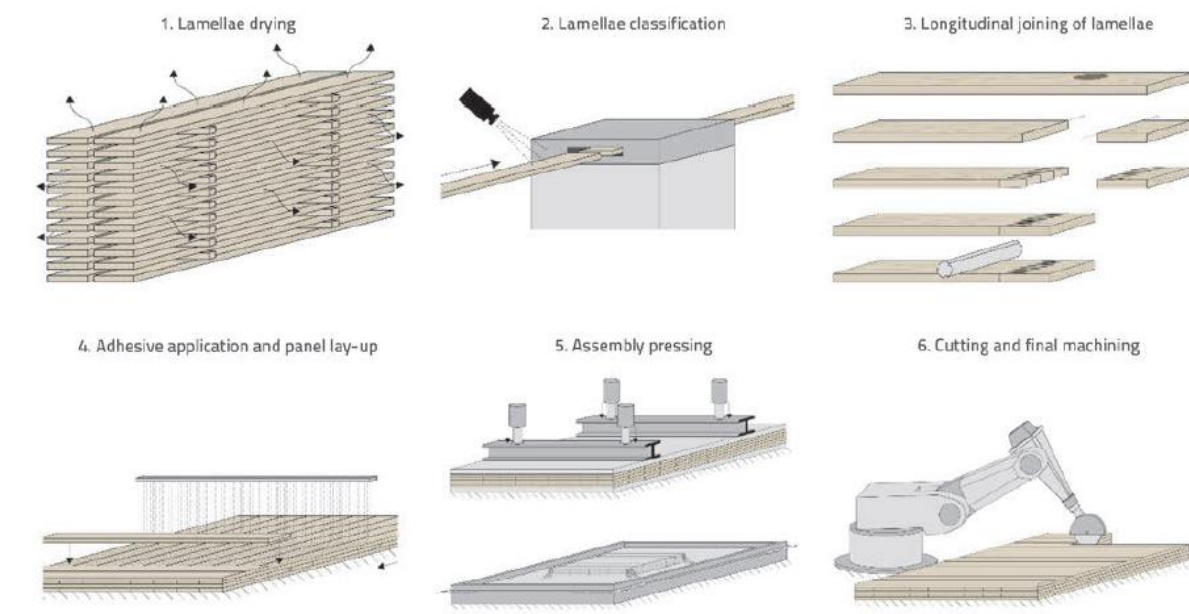

Figure 20 Scheme of CLTs production process [20]

#### 4.4 Application

CLT panels have a wide variety of applications, mainly because of their high load-bearing capacity, which makes them even suitable for constructing higher buildings with attractive and natural appearance. In addition, they can be used as cladding material or internal decorations. The high level of prefabrication and the corresponding short assembly time satisfies building

requirements for a great deal of economical design solutions. Typical CLT applications include [8]:

- load and non-load bearing walls,
- solid partitions,
- floor and ceiling elements,
- roof elements,
- stairs,
- cantilever floors,
- load bearing lift shafts.

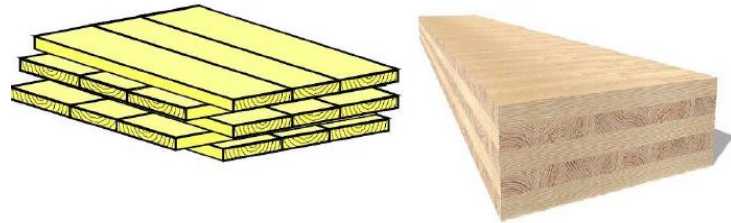

Figure 21 Scheme of a cross laminated timber element [26]

It should be said that today over half of all CLT produced finds its use in residential applications being followed by educational institutions, commercial spaces, and government and public buildings [2]. Moreover, with the right choice of structural components, CLT can be combined with almost every type of construction material. Such hybrid solutions may enable better efficiency or use of materials for certain building applications, which would be more cost effective when used in taller buildings, especially the ability to cover larger spans while supporting loads and its own weight.

#### 4.5 Construction

The main idea behind prefabrication is to reduce manpower and enhance automatization, thus reducing the overall price of a project. As a result, expenses are more likely to be related to material costs rather than work costs. Considering the fact, that much of the work is done in a controlled environment the system is more precise, hence reducing the insufficiencies



Figure 22 CLT prefabrication and on-site assembly [26]

within the design. Furthermore, on-site assembly is faster and requires minimal equipment, therefore circumstances such as severe weather impact on delays, is minimized. On the other hand, there are certain weak points such as increased technical work, transport care and storage care. Planning plays a crucial role in assembly, transportation and storage issues, mainly



because late changes of the design clearly mean higher costs of the prefabricated CLT product [8]. Large CLT panels are another concern, since not all products can be delivered with trucks on regular roads, there are some cases in practice where boats were engaged with delivery (*Treet* -Bergen) [29]. Once on-site CLT products must be stored and protected from weather conditions and exposure, so as, to minimize the problems that could potentially appear during construction, related to wetting moisture or later in the building life. The area of on-site care and construction would be discussed into details in the 5<sup>th</sup> chapter. In conclusion, in order to deliver a successful project, CLT construction requires high level of engineering from its design throughout the entire construction process.

#### 4.6 Structural design

The current version of the European standard for timber structures *Eurocode 5*, does not include the design procedure for the relevant states of stress; in and out of plane. However, the future version is likely to incorporate all relevant states. The design procedure can be found in some national regulations such as [51], where engineers can use technical solutions and manufacturer issued specifications. Special precaution should be applied on connections, which in some cases such as earthquake and fire scenarios defines the behavior of the whole structure.

The Distribution of *load out of plane* over a cross section is considered only in layers which are parallel to normal stresses. Perpendicularly laid layers are ignored in calculations. For this reason, loads on horizontal elements are only resisted by boards or layers that are parallel to the span, whereas on vertical elements parallel to the height. Normal stresses  $\sigma(z)$  caused by the bending moment  $M(x)$  along the span can be seen in (*Figure 23*) and calculated with equation (4.1). From here, the maximum carrying capacity of normal stresses can be checked using equation (4.2). Further design principles and calculation examples can be found in the design manual [51].

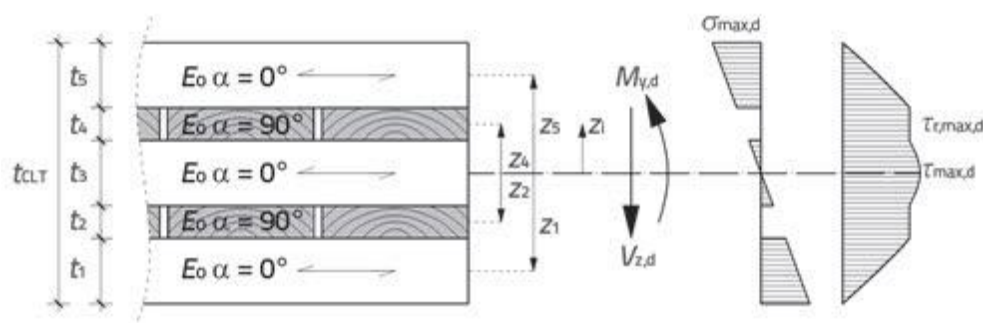

Figure 23 Stress distribution for CLT element loaded out-of-plane [20]

$$\sigma(z) = \frac{M(x)}{EI_{\text{eff}}} \times z_1 \times E_1(z_1) \quad (4.1)$$

$$\frac{\sigma_{\text{max,d}}}{f_{\text{m,CLT,d}}} \leq 1,0 \quad (4.2)$$

It should be also mentioned that number of European CLT design manuals, which follow the European reliability concept, propose a material safety factor  $\gamma_M = 1.25$  and property modification factor  $k_{\text{mod}}$ , same as for solid timber (0.5-1.10) [20].

In the design process weather effects such as moisture, creep and shrinkage of CLT, should also be considered separately, yet in most cases values and experience from similar materials are applied [14].

## 4.7 Performance

CLT performance primarily depends on the moisture performance or wetting and fire performance of the wood.

### 4.7.1 Durability performance and moisture behavior

From the literature survey, it was found that the most relevant information on the topic of CLT and moisture is located in scientific publications, nonetheless the lack of knowledge and research in this area attracts values and regulation from sawn timber and similar products to be dominant into practice.

Publications widely accepted that the upper safe moisture content in timber structures is 17% and should not exceed 20%. CLT as a biodegradable wood material, under conditions that overcome the accepted upper limit for water content promotes excellent conditions for fungus and micro-organisms growth. The growth of this organisms is likely to cause damage and decay of the product, which eventually leads in loss of structural strength and hygiene [18]. In addition, the change in water content causes different amount of swelling or shrinkage in different direction. The volume change, strength-decrease and fungus process formation are essential to be considered during transport, preparation and construction process. Contrary, if the moisture from the exposure and wetting is not handled and dried properly from the product during the process, moisture safety can trigger an alarm.

#### 4.7.2 Fire performance

In the case of fire, fire performance of the material is crucial for reducing the risk of fire damage of the timber structure. The charring behavior of wood or the char layer, which forms when wood burns, slows down the whole process. Although, for CLT same principles as wood apply, the product might behave different, mainly because of the glued composition and joints between the boards, which can locally lead to increased charring [45]. The charring behavior is



Figure 24 Cross section of a charred CLT element [14]

defined by density, thermal conductivity, moisture content and permeability of the product. However, increasing the thickness of the panel also improves the performance [14]. The conservative *Eurocode 5* model for timber members is mainly used to determine the cross section of charred layer of CLT during fire.



## 5. On-site moisture protection

### 5.1 Chapter outline

As it is known it is important to protect wood from water during transport, storage, construction and service. On-site moisture might not be a concern for the traditional light wood frame construction, but for the construction of modern larger and taller wood buildings it is certainly among all stages the most challenging, considering the amount of possible moisture exposure.

With the increase in building height and area, which prolongs the exposure to the environment, and the increase in speed of construction that unables longer time for drying, the construction moisture management is becoming increasingly important no matter the fact that wood is in general quite resilient to moisture content changes if kept within certain limits [23]. Although, CLT as a material has similar mechanical properties to number of other construction materials, the use of timber brings up the construction moisture safety issues. In most climates wetting is the primarily concern, especially wet Nordic climates. Nonetheless, in rare cases of extremely dry periods dimensional instability of the material is also possible, humidification may become necessary to reduce the excessive dimensional changes.

When introducing the appropriate on-site protection for the construction phase, various aspects should be considered, this include [21];

- *Weather conditions (e.g. rain, snow, relative humidity, temperature, wind direction)*
- *Wetting potential of the product, water absorption of the wood*
- *Drying ability of the material, or the CLT assemblies*
- *Durability risks caused by wetting and insufficient drying (e.g. mould, decay)*
- *Appearance deterioration risks or discoloration of exposed elements*
- *Location of the elements in the building (e.g., interior/external wall, floor, roof)*
- *Cost of delays because of potential wetting problems*
- *Cost of force drying, space heating or dehumidification*
- *Cost of the required protection methods and scheme coordination*

Methods of on-site moisture protection vary from simple ones, including prefabrication in order to reduce on-site exposure time, delivery coordination with schemes, reducing on-site moisture sources and introducing material coating or covers with wraps. More sophisticated methods

include covering horizontal building parts with pre-installed membrane and in some severe cases temporary roofs.

Timber products have different MC specifications at the time of manufacture and thus should not be neglected when the decision for the required protection is made. The products are in most cases manufactured at MC levels from 11% to 15% but it must be acknowledged that there is no assurance that the MC will not rise or fall after manufacture [16].

## 5.2 Moisture content measurement

The measurements of wood moisture content can be separated into two main approaches (Figure 23). With the direct approach, the moisture content is determined by oven-drying or water extraction. Indirect measurements use the physical properties of wood as an assistance to determinate the MC, and thus are crucial for on-site measurements.

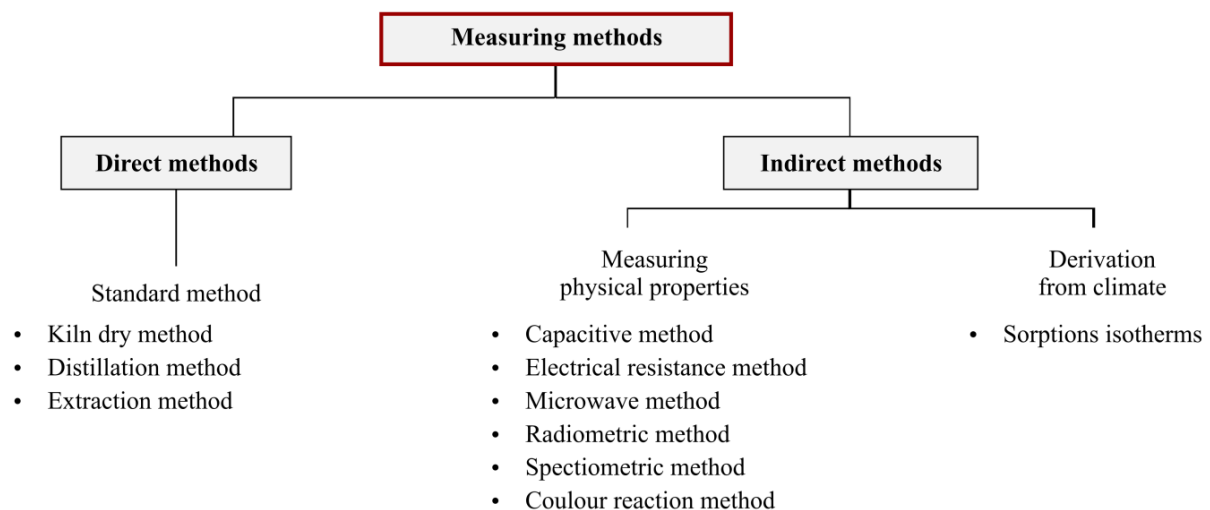

Figure 25 Scheme of methods to determine wood moisture content [23]

The MC of the timber products should be measured and monitored on a construction site to help make right decisions regarding protection, drying, and other needs. The two most important indirect and commercially available methods use a portable moisture meter typically based on electrical resistance or capacitance [21]. Because of their importance in on-site measurements they would be discussed into details.

### 5.2.1 Resistance method

This method uses the indirect approach, the electrical resistance or conductivity of timber and water, with the last having much higher conductivity than wood, which results in decreased resistance with higher MC. Finally, the correlation between the two determinates the moisture

content of the product. It is also worth to mention that the acceptable accuracy is  $\pm 1,0\%$  for wood MC between 6% and the fibre saturation point, with the accuracy decreasing considerably after the fiber saturation point, and electrical resistance reaching very high values below 6%. Another factor that could possibly influence the electrical resistance result, is temperature, higher temperature lower resistance, yet modern professional moisture meters allow a direct temperature calibration [23].

On-site measurements in practice should be conducted away from knots and pitch pockets. The two pins or electrodes are inserted into the timber or attached on the surface with a defined distance, commonly 30 mm. Furthermore, the orientation of the electrodes should be perpendicular to the grain or at  $90^\circ$ , mainly because the variation of the measured data will be smaller when compared to grain direction. Non-insulated or coated metal pins provide highest MC of the wood between the two pins, whereas on the other hand when the pins are coated, i.e. insulated, they provide MC between the two tips and measure at a specific location, as indicated in (Figure 27) [23].

When measuring and monitoring MC of CLT or Glulam specimens, the main rule of electrodes in the same lamella should be followed.

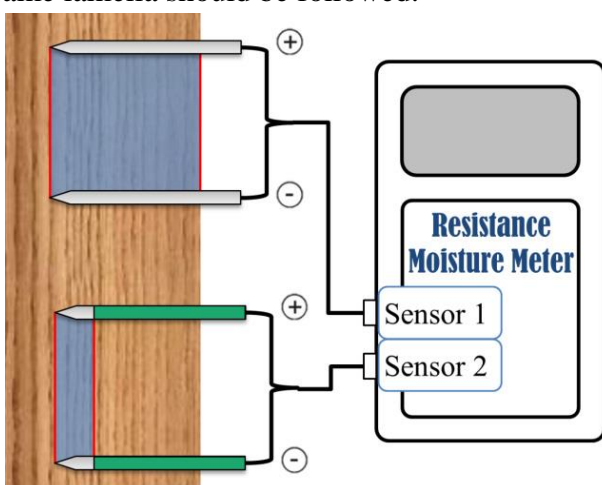

Figure 27 Schematic of area measured by resistance method using insulated and non-insulated electrodes [23]



Figure 26 Commercially available device using the resistance method [23]



Figure 28 Measuring MC of a CLT panel using a resistance method device [44]

### 5.2.2 Capacitance method

The capacitance method is based on the dielectric characteristics of the materials, timber changes its dielectric properties to its moisture content. For measurements, the meter that covers a large volume of wood, which is equal to the meters' footprint to a depth of about 25 mm is placed on the wood surface [23]. The condenser and the applied frequency signal to the transmitting electrodes and received by contact electrodes delivers an accuracy for moisture contents from 2 % up to the fibre saturation point. Measurement errors vary approximately  $\pm 2\%$  and in cases of 40-50% MC the accuracy is reduced. Main advantages of the device are; quick and easy use on a construction site and the advantage of not leaving electrode holes in the timber [21].

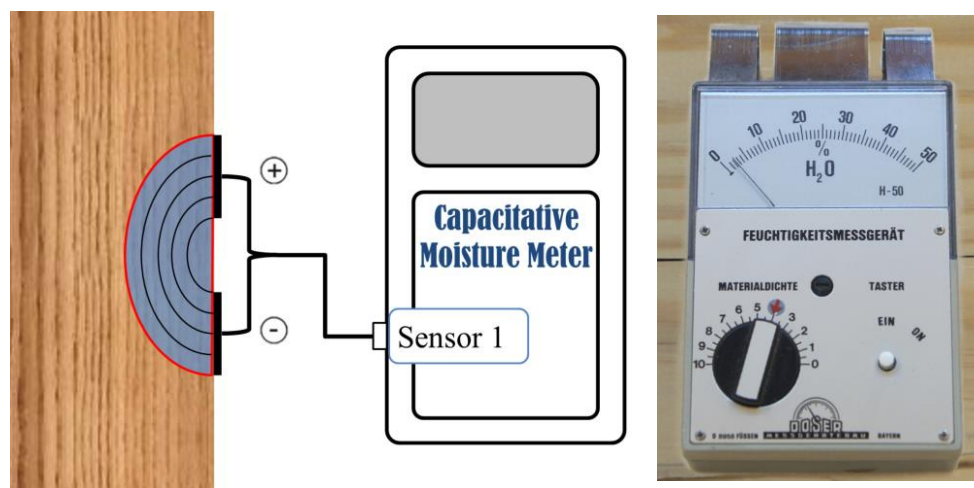

Figure 29 Schematic of area measured by capacitance method and a commercially available device [23]



Figure 30 Measuring wood moisture content using a capacitance-based meter (left) and a resistance-based meter (right) [21]

### 5.2.3 Measuring average MC and surface MC

When measuring the MC in timber products with the resistance and capacitance method different locations in the structure should be considered. The points are primarily determined by on-site conditions, risk of damp and positions with weakest drying potential. The carried on-site measurements show the average MC of the cross-section, however the surface MC should not be ignored, considering microbial growth [21].

#### Average moisture content

The on-site measurement of the average MC in timber products with the resistance and the capacitance method, should be conducted on number of random pieces and according to the following standards:

*EN 13183-2* Moisture content of a piece of sawn timber, estimated by electrical resistance method and *EN 13183-3* Moisture content of a piece of sawn timber, estimated by capacitance method.

The average MC measurement in line with EN 13183-2 is more often used and shown in (Figure 31).

#### Surface moisture content

For the surface MC it is necessary to be checked before enclosing the timber product, because it is crucial to control further risks of decay and microbial growth. In accordance with the regulations, when measured, the surface MC should not be above 18%. In case the product gets wet, due to rain, incorrect storage or hybrid concrete solutions - drying (either naturally or artificially with a fan) should be considered. It is worth to mention, that the MC in the inner part of the

#### Measuring moisture content

Measuring average moisture content in a piece of wood – electrical resistance method.

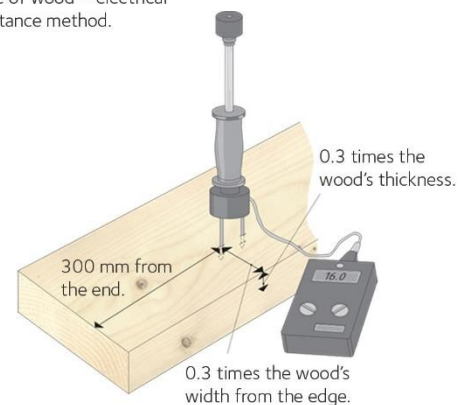

Measuring surface moisture content in a piece of wood – lay the electrodes against the surface, parallel with the end.

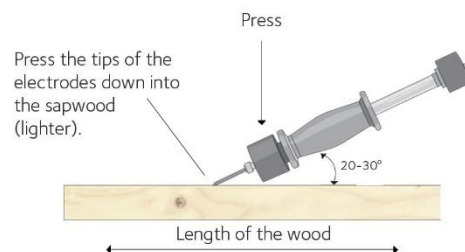
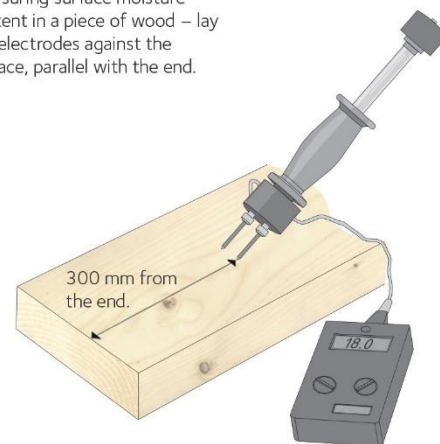

The lower part of the electrode can be filed down to achieve the correct angle.

Figure 31 Measuring average and surface MC of a timber product according to EN 13183-2 [58]



product will not normally fluctuate in term of short exposure or wetting [58].

The surface MC measurement in line with EN 13183-2 consists of three measurements close to each other with the calculated average verified with the relevant requirement as presented in (Figure 31).

### 5.3 Wood moisture levels and durability

The MC level of timber products does not vary only between different pieces, but it also varies in the cross-section of every individual piece, thus adding additional stresses in the product. This wood property is also referred as the *moisture gradient*, which if controlled will prevent uneven deformation. In most cases the inner part will have higher MC than the surface, particularly after drying or storage. This content will remain the same or slightly change, unless severe wetting occurs [23].

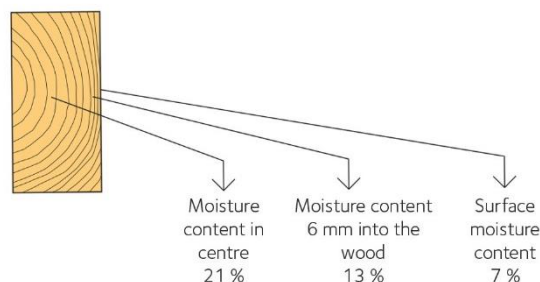

Figure 32 Cross-section MC variation after drying [58]

As mentioned earlier (2.3), moisture in timber products exists either as *bound water* in the cell walls or as *free water* in the cell cavities. When the product dries, the free water evaporates first and the fibre saturation point is reached, averaging 28-30% MC. This is the point where all wood properties are related to the bound water in the cell walls.

For the construction phase it might not be the most critical, but wood loses or gains moisture depending on the environment. This exchanges with the surrounding environment are called *sorption* (causing swelling) and *desorption* (causing shrinkage). When the exchange does not include liquid water, the MC will not exceed 30% or the fibre saturation point, excluding extreme conditions.

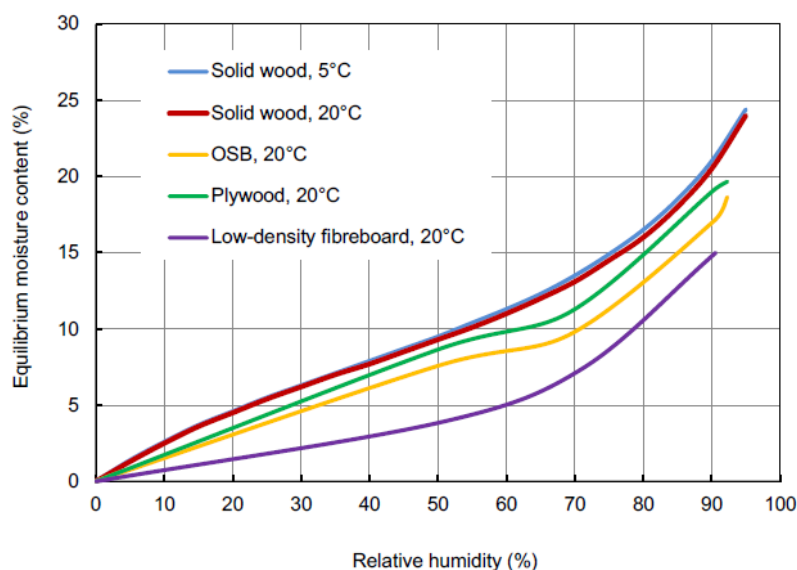

Figure 33 Isothermal sorption curves – EMC of solid timber and timber products [59]

In practice wood never reaches EMC because of the ever-changing on-site conditions, nevertheless the controlled fluctuation of MC over a small range is considered as EMC. It is also worth to mention, that wood products with a higher level of added adhesives have a lower EMC compared to other timber products (*Figure 33*) [21].

Occurrences correlated with durability of timber products, such as; fungi, mould and decay are predominately associated with wetting caused by liquid water, hence preventing exposure to moisture is fundamental to avoid them throughout the construction phase and extend durability.

Considering only the construction phase, where timber products face environmental exposure, it is certainly that liquid water sources such as; rain and snow have a much higher influence on the products' performance than sorption/desorption alone, and as such, the process to a certain degree can be ignored. Another intricacy of the process is the unequal water absorption throughout the wood, with *sapwood* being more absorptive than *heartwood*, and thus having lower natural durability. This brings the reason, why locations such as, end grains and joints start to deteriorate sooner, especially under warm conditions.

In order for *decay fungi* to appear in an EWP, suitable temperature and MC of approximately 26% are considered as marginal conditions, which if met would take months for detectable damage or strength loss to occur. Nevertheless, in case of severe wetting and rapid rise in MC, ranging 40% to 80%, decay and strength loss happen rapidly, even in weeks. In the interest of prevention, the upper safe MC limit of 17% for EWP and timber construction was introduced and widely accepted, that is because decay fungi produce additional water in the process [21].

*Mould* on the other hand, does not affect the strength of the product and is more related with the RH of the surface, or so-called water activity of the product. Marginal conditions, which lead to mould appearance are RH of 80% and temperature, between 20-25°C, such conditions take months for moulds to start on non-resistant timber products [42].

Apart from mould and fungi, *discoloration* is another issue that should be considered. It can be caused by metals in case of severe moisture, such as iron staining. As a problem it is crucial for exposed steel-timber members and components, which will not be covered in the final building appearance. In addition, if the product is not naturally durable, chemical treatment should be considered to increase its resilience [42].

#### *5.4 Wetting and drying potentials of EWP*

The wetting and drying potential of an EWP primarily depends on inherent factors such as; method of manufacturing, wood specie, internal voids, end grains exposure, adhesive contents and, if present surface treatment. In addition, the amount and speed of absorption, depth of water penetration and the amount of moisture gained while exposure, correspond with the weather conditions; rain frequency, rainfall amounts, humidity levels, wind speed-direction, and temperature. In conclusion different materials or assemblies absorb and dry at different rates, with drying rates being normally lower than wetting rates.

To start with wetting, the importance of the wetting period is greater than the total amount of rain falling on the surface, consequently rainy winter climates, with prolonged periods of rainy days, propose a higher treat to EWP and exposed on-site assemblies. However, in climates with heavy snow falls, snow is considered as an immense wetting source and it is necessary to be removed from the assemblies before it melts [21].

Moreover, the location and orientation of the EWP in the assemblies has a large impact on the wetting and drying properties. It can be easily understood that horizontal components are subjected to more wetting compared to vertical, which normally receive smaller amounts of wind-based wetting, thus horizontal require more time for drying to occur. Additionally, ground components face further wetting risk, due to standing water and ground moisture. Finally, for drying rates, factors such as; RH and ventilation are crucial [32].

The overall on-site protection and strategy should be based on conditions and circumstances that are considered of vital importance when evaluating the wetting and consequently drying rate of the EWP components and assemblies;

- *Vertical and horizontal components - end grains, based on top or with direct ground contact, deserve special attention.*
- *Small gaps and delamination between members, such as CLT or Glulam, should also be observed.*
- *The combination of end grains and small gaps in large size - massive EWP, should be separately examined, particularly on horizontal surfaces.*
- *Large and exposed metal joints and connections, with focus on staining.*
- *MC of exposed assembly components covered with low-permeance membranes or insulation.*



## 5.5 On-site moisture management

### 5.5.1 General

All activities, from the design process until the final construction phase, which are implemented in order to minimize the risk of water or moisture entering the structure, and causing further damage, define the term *moisture management*. As moisture can develop from various sources; built in moisture from production process, transport or storage of products, surrounding air or outdoor exposure; regulations, when EWP are used as load-bearing elements, require a moisture control plan that covers all building phases. As indicated, the moisture control plan should be a collaborative work between the designers, construction company and manufacturers of EWP. Additionally, it is recommended to contain the upper expected level of on-site MC in different products and foremost the protection scheme.

In practical terms, today two main approaches, which can be introduced in the design and construction stage, dominate moisture management; moisture prevention (entering in the structure) and use of highly moisture durable materials and constructions. Moreover, according to FPInnovations the “4D principle” - Deflection, Drainage, Drying and Durable materials (*Figure 34*) is also emerging into practice [21].

Having this in mind, the decisions made regarding moisture management could eventually influence the design process, from the materials used to the organization and duration of the construction phase.

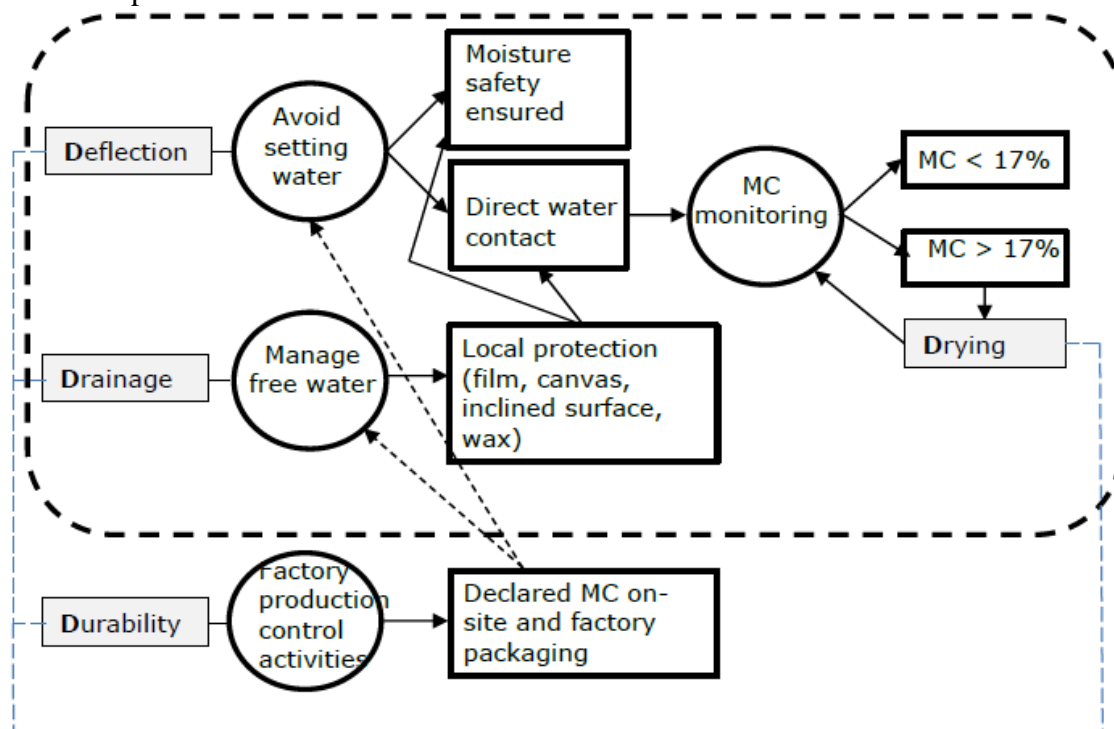

Figure 34 On-site moisture safety activities and MC monitoring scheme according to the 4D principle [22]

### 5.5.2 Overall on-site weather protection

The highest priority for on-site protection is to reduce wetting. Consequently, the decision upon the required and proper protection principles, should be assessed with regards to the product/assembly performance, such as wetting and durability, discussed earlier. Furthermore, the cost of different levels of protection could also be of great importance to the investor, and therefore should not be overlooked.

The following selection of common on-site principles is found in the literature survey, and it is recommended to be followed in any kind of timber construction:

- **Prefabrication**

The main aim behind this principle is to reduce the on-site exposure time. Considering the fact, that much of the project is done in a controlled environment, on-site assembly is faster and requires minimal storage time, circumstances such as weather wetting hazards are significantly lower.

- **Construction phase proper timing - if applicable**

In cases where, climate and the building concept allow, construction phases before enclosure should occur in a drier season.

- **Material delivery coordination**

Deliveries should be planned to match the pace of the construction phase, thus avoiding on-site overstay. The following routine checks are required with every on-site delivery [58]:

- Proper packaging and damage check
- Quantity check
- Size and dimension check
- Grade check
- Dirt and mud inspection
- Moisture content check



Figure 35 Good practices in material delivery [58]

- **Proper storage of materials**

Products and packs should be stored flat with acceptable clearance, at least 300mm above the ground in well-ventilated shelters, where air can freely circulate (Figure 36). In order to avoid bending and additional stress, a series of battens should be placed under the pack. Asphalt, concrete and gravel are considered as

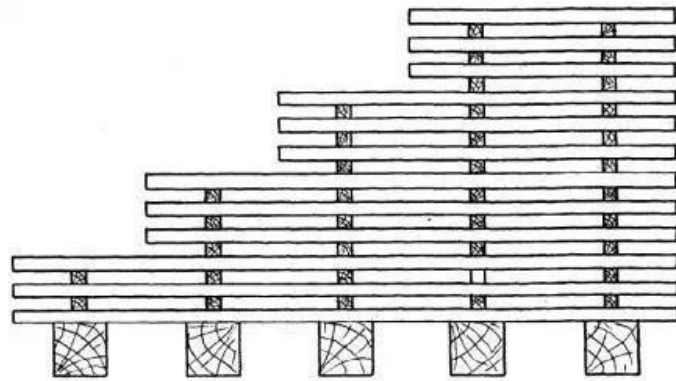

Figure 36 EWP proper on-site storage - scheme [37]

suitable floor-storage places, where moisture does not rise from the ground, and therefore the risk of water damage is minimized [21]. In case of heavy snow fall, snow should be removed before storage. Moreover, it is necessary for the storage place to be protected from precipitation and located in shade, especially during spring and summer; direct sunlight and warm temperatures may lead to condensation under the cover, which can rapidly increase the risk of microbial development on the outer layer [37]. Finally, waste should be recycled and sorted, as wood can be reapplied or used as an energy source.

- **Proper use of wraps and tarps during storage and construction**

Wraps and tarps are used accordingly to the ventilation and air circulation principle. Manufacturer's protected and sealed products throughout transport, should be left wrapped on-site for as long as possible, theoretically even after the assembly process. In the protection and wrapping procedure transparent covers are generally avoided. In case



Figure 37 On-site storage of manufacturers' sealed CLT elements  
– Project: Skipet [by author]

of damaged or teared wraps, the product should be checked for MC, and if water is found, dried accordingly; warm periods placed outside and cold periods inside with a heating fan [58]. Other more advanced sealing methods include; protection of joints by tapping, installing temporary protective coating on members or assemblies and in severe cases temporary roof constructions,

which in recent projects are found to be unnecessary. Despite the fact, that such protection methods typically require more work and funding, the effort may result in savings in time and costs elsewhere [21]. As a final highlighted point, MC checks are an obligation before the product is to be used or assembled.

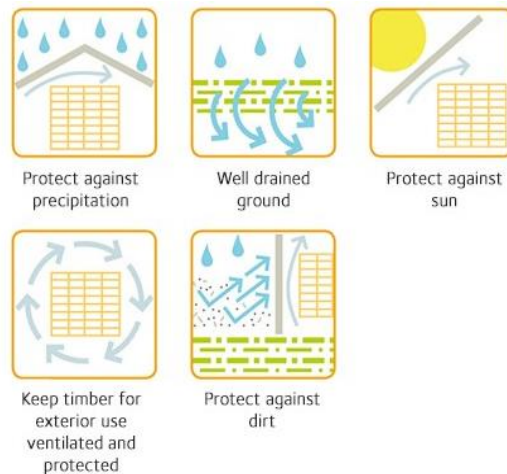

Figure 38 Principles for proper on-site storage of products[58]

- **Adequate end-grains protection**

As mentioned earlier (5.4), exposed vertical and horizontal end-grains, because of their moisture behavior, is recommended to be covered using a water repellent coating or tarpaulin (Figure 39).



Figure 39 Waterproof tarpaulins used as end-grains protection on Glulam columns, while construction – Project: Skipet [by author]

### 5.5.3 Guidelines for different EWP on-site moisture protection

The following brief summary of guidelines is based on the carried literature survey:

#### ***Glue laminated***

- *Glulam*

A primary coating must be added before delivery, additionally a secondary on-site coating is advisable and reduces damage risks. Precaution in “weak spots”, gaps and cracks, since water penetrates easily into the inner of the material. It is essential to prevent inner wetting, considering the reduced drying rates, whereas surface is a minor concern. Exposed end-grains deserve special care.

- *CLT*

The same wetting and absorption performance principles apply as Glulam, end-grains exposure should also be considered. Protective covers and waterproof tapes are advised if no-additional temporary roof is used, mainly because of the exposed area. Elements should be left dry to the required MC before any additional assembly or enclosure occurs.

#### ***Composites***

- *LVL / LSL*

Due to the water absorption potential, especially along the edges, measures, such as, membrane and even temporary roof constructions should be reviewed. As discussed later, in the *Mjöstårnet* project, membranes alone are not a solution if LVLs’ edges are exposed. A practical solution would be to choose dry weather when installing the elements and adding waterproof tape along the edges.

- *Plywood / OSB*

The rule of sealing and ventilation principle should be followed. Because of the immense absorption rate and medium drying rate, further notice to its’ edges protection, such as, sealing or waterproof tapping, should be taken.

#### *5.5.4 Guidelines for CLT building assemblies on-site moisture protection*

The following outlined guidelines are only suggestions for improved on-site moisture protection of CLT assemblies:

- Plan and predict moisture damage, with a moisture management agenda.
- Prefabrication is essential for short building time.
- CLT delivery optimization, along with properly protected and ventilated on-site storage, no longer than a month. Regular MC measurements of elements and condensation under covers should be considered.
- Adding a protective cover is always safer than no-cover.
- If possible, arrange assembly on dry days or weather. Apply weather protective membranes as soon as possible.
- Install sensors for MC, temperature and RH measurements in various locations, consider high-risk areas. Additional, weekly checks with a hand-held moisture meter are also advisable.
- Reduce or cover exposed openings.
- Clear water immediately after severe wetting or snow after snow fall.
- Waterproof tapping of joints and edges might be helpful.
- Observe gaps and cracks for damage regularly.



## 6. Implementation into reference projects

### 6.1 Chapter outline

This following chapter introduces a group of selected timber engineering projects in Norway and focuses on their moisture management agenda. The carried literature survey and on-site interviews under no circumstances should be considered as a result of a complete research.

### 6.2 Skipet

The project owned by GC Riber Eiendom AS, is going to be Bergen's first office building made entirely from wood and accordingly to the passive house standards. It is planned to have an area of 14 240m<sup>2</sup> and to be completed by 2020. The structure consists of steel and concrete foundation for stability and glass facade, which allows the use of beams



*Figure 40 Illustration of the Skipet project [60]*

and columns. The bearing construction comprises Glulam beams and columns, with CLT floor and shaft elements [60]. The construction process is performed without any additional weather protection, such as temporary roofs, which according to the contractors is considered unnecessary.

The following remarks are observations from the authors visit to the active construction site, as well as answers to predetermined relevant questions regarding the process of construction and moisture safety goals; (personal communication, May, 2019)

- *Glulam and CLT elements are adequately sealed and wrapped during transport by the products' manufacturer (Figure 42) – Splitkon AS.*
- *Routine checks by workers, upon delivery to confirm that packages are intact (Figure 42).*
- *High level of prefabrication and short assembly time. Maximum on-site storage time about 2 weeks.*





Figure 41 Construction site of the Skipet project in Bergen. Half of the building is enclosed (right). Protective tarpaulin covers give protection to the end grain of the panels and columns [by author]

- *Manufacturers declared MC on delivery of both, CLT and Glulam is 12%, and should not exceed 17% before assemblance. – Splitkon AS technical brochure.*
- *Regular inspection and MC measurements upon delivery and throughout storage.*
- *Proper storage of products following the ventilation and air circulation principle, with a suitable floor-storage place (Figure 42).*



Figure 42 CLT and Glulam elements on-site delivery, routine checks and preparation for on-site storage of elements [by author]

- *No recorded microbial growth, unusual smells or discoloration of products. Dirt appearance on assemblies is cleaned on regular intervals.*
- *Despite the fact, that a scheme has been developed for microbial growth testing, critical MC levels, exceeding the max value were not registered.*



Figure 43 Construction site of the Skipet project in Bergen, material storage location and crane handling

[by author]

- According to the on-site interview and data, no microbial growth has been recorded throughout the building process so far. However, free standing water and snow were considered as high risks, thus cleared regularly.
- In case of severe damage to some products, additional elements were available if needed.
- Additional artificial heating devices were considered as inessential and have not been used so far.
- Tarpaulins were also used to protect exposed vertical and horizontal end-grains in the assembly (Figure 41).
- Locations of high moisture risks, such as; gaps between horizontal elements lamellas, CLT wall elements and concrete floor connections, and unusual stains were also observed. Although, no indications of serious damage were found, they might require a further in-depth study (Figure 44).



Figure 44 Observed high-risk locations in the Skipet project; CLT-Concrete connections, covered stains and gaps. No significant damage is found [by author]



In conclusion, in accordance with the opinion and experience of the manufacturer, and contractor in the project, additional weather protection is not necessary when following the on-site principles, mainly because, if surface wetting occurs, it dries fast.

### 6.3 *Mjøstårnet*

*Mjøstårnet* is an 18-storey timber building, located in the small town of Brumunddal, about 140 km north of Oslo and currently is the highest timber building in the world, with its 85.4m. The building owner is AB Invest AS, main contractor is HENT builds and Moelven Limtre is the subcontractor for structural timber, with Stora Enso as a CLT supplier. Additionally, several other companies have been involved in different tasks [30]. From structural point, it is a combination of Glulam;



*Figure 45 Illustration of the Mjøstårnet project [30]*

columns, beams and diagonals; and CLT shafts and stairs, with total amount of 2600m<sup>3</sup> timber structure. Glulam is the primary load bearing element for all vertical and horizontal loads, and CLT is used as a secondary load bearing element for staircases and elevator shafts. Prefabricated slabs, combination of Glulam and LVL, are located on the first ten floors, and

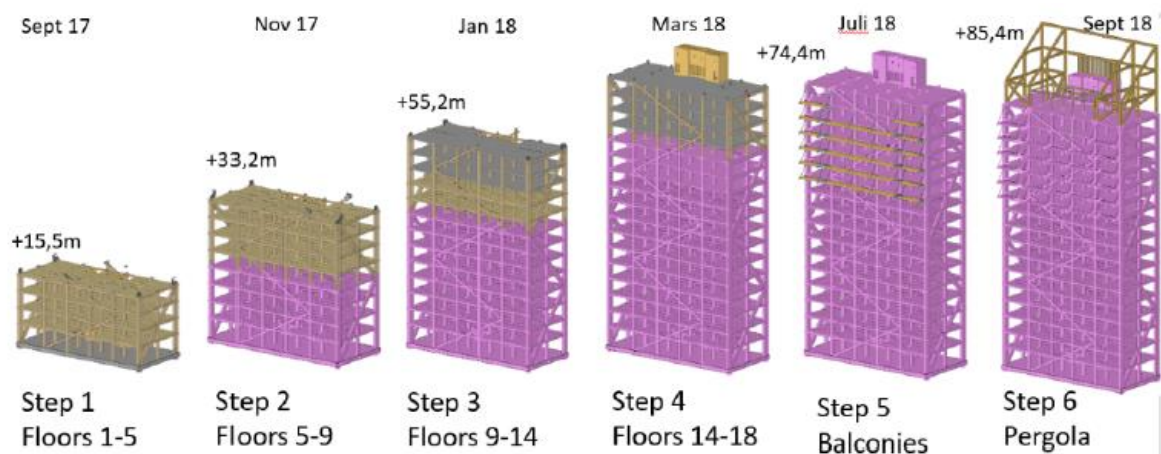

*Figure 46 Construction site of the Mjøstårnet project. Installation of the pre-assembled Glulam structure and CLT shafts [61]*

concrete decks in the upper floors are used to reach comfort criteria and acoustics regulations [61]. The installation process, was mostly about prefabricated elements on-site, with the main difference being the on-site assembly of complicated trusses (*Figure 45*), which offered a quicker production process and made the procedure faster and less expensive [30]. The assembly process was performed without any additional temporary roof construction, which was considered as troublesome and unnecessary.

The following notes are reflection of the literature survey and information published regarding the moisture management agenda and on-site moisture safety goals by the parties involved in the project;

- *Direct weather exposure while construction.*
- *Highest level of prefabrication with on-site members assembly, and minimal on-site storage time.*



*Figure 47 Installation steps with time intervals in the Mjøstårnet project [61]*

- *Plastic covers or wooden plates were used as end-grains protection for columns, diagonals and walls (Figure 48).*
- *The horizontal floor elements; the prefabricated Glulam-LVL slabs were protected from the upper side with a waterproof membrane.*
- *Regular MC measurements in numerous places and depths; upon delivery, throughout storage and installation process.*
- *In case MC levels approached the imposed max value after walls installation, artificial warm air was distributed and dried the structure in a controlled way.*

All things considered, the gained experience from the project reveals that both Glulam and CLT can cope well with weather exposure while construction, if storage and assembly time

until enclosure is fast enough, with prefabrication and planning being crucial. A lesson learned from the subcontractor, is LVL's poor moisture behaviour. The prefabricated Glulam-LVL slabs deserve special attention, mainly because LVL soaks up water along the edges and consequently they require side protection using either waterproof tapes or epoxy, membrane covers are found to be insufficient [61].



Figure 48 Plastic covers as end-grains protection [30]

#### 6.4 Treet

"Treet" - or "The Tree" is a 14-storey sustainable and urban high-rise building project located in Bergen. The main developer is BOB Eiendomsutvikling AS, engineering is done by Sweco AS, and Moelven Limtre AS and Kodumajatehase AS – Estonia are responsible for Glulam, CLT and prefabricated modular apartments. The design concept is based on glulam



Figure 49 Illustration of the Treet project [63]

frames - columns and girders act as a primary load bearing system, and apartments made as prefabricated building modules [63]. The prefabricated modules have a traditional timber structure for floor, walls and ceiling, and can be stacked for 5-storeys without any secondary load bearing system (Figure 48). Additionally, each one complies with the passive house standard. CLT is used for; corridor walls (15m long, 5-layer panels), elevator shafts, staircases, balconies and floor constructions. In order to successfully cope with the wind and improve dynamic behavior, additional weight was added by the concrete elements above the 5<sup>th</sup> and 10<sup>th</sup> floor, and on the roof, which also serve as foundation for the modules - the so-called power floors [64]. The assembly of "Treet" was mostly about installation of prefabricated modules or products on site, which required more planning at the early stage of the project, resulting in



better construction, and faster installation process [29]. The process was performed with additional temporary roof constructions, and since it was not possible to use the traditional roof over roof tent - considering the height of the building, the solution was to add temporary roof elements over exposed CLT corridors, staircases and elevator shafts and install prefabricated modules sealed. Moreover, the concrete slabs or power floors were used as additional temporary roofs by adding a waterproof membrane on top. It should also be mentioned that during construction Bergen hit an all-time high record of rain, with 3076 mm rain in 2015 [64].



*Figure 50 Construction site of the Treet project. Installation of the prefabricated modules [62]*

The following information are an outcome of the reviewed literature and gathered data concerning the moisture management agenda and construction moisture safety goals by the developers and contractors involved in the project;

- *Temporary roof adjustable constructions are used to protect exposed CLT elements and joints. Modular apartments were sealed and waterproof, any additional protection was considered as unnecessary.*
- *High degree of prefabrication, with almost no on-site storage time, which required a detailed delivery and assembly plan, so as to arrange the arrival of the modular apartments from Estonia in three stages. Tower crane and scaffolding systems were used during the assembly time, to optimize the process.*
- *The modules were fully sealed - protected during transport and delivered by boat. Glulam frames and CLT elements arrived by truck and were instantly erected, with no additional on-site storage.*

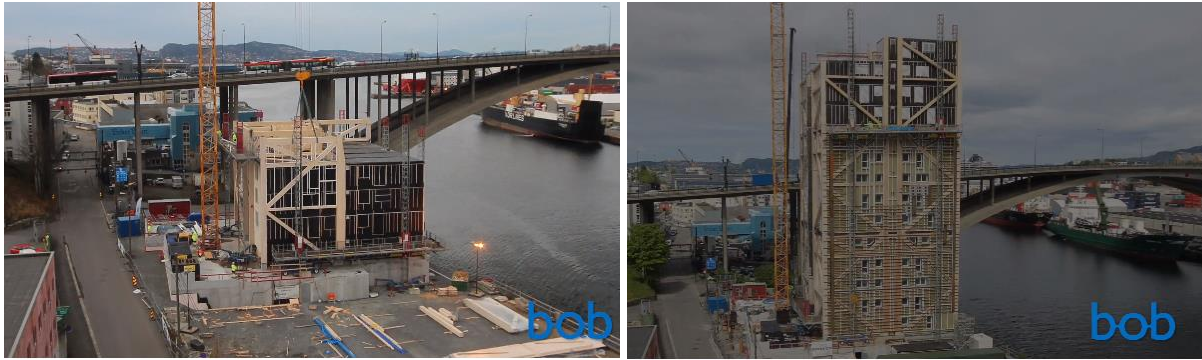

*Figure 51 Construction site of the Treet project. Installation of the pre-assembled Glulam structure and CLT shafts with the tower crane and scaffolding system [62]*

- *Regular MC measurements after assembly, in numerous places and depths.*
- *Plastic covers were used as end-grains protection for Glulam columns (Figure 52).*

A modular step-by-step construction method implemented in the *Treet* project requires far more engineering resources at an early phase of the project, in order to verify solutions and make precise delivery schemes, which results in faster construction and assembly, consequently reducing the exposure and wetting risks during construction.



*Figure 52 Protective plastic covers give protection to the end-grains of the Glulam columns (left). Installation of CLT elevator shafts (right) [63]*



## 7. Conclusion and recommendations

### 7.1 Conclusion

Wood as a material has unique characteristic related to moisture sensitivity, which not only influence the physical and mechanical properties but also impose great risks associated with durability, such as, biological attacks and fungal decay. As a result, prudent control of moisture sources while construction and service is essential. In addition, different EWP or assemblies require different on-site protection system principles. These systems incorporate moisture protection principles from transport, during erection and even after wetting. Compared to other properties, *MC* is easily measured, thus providing important information for evaluation of the current state, which helps assess further decisions in the building process. The gathered data revealed that *MC* near the *FSP* (26-28%) poses structural damage risks, mainly because of decay. Additionally, *MC* above 20% promotes mould growth, hence it is widely accepted that the upper safe moisture content in timber structures is 17% and should not exceed 20% during construction or service. Furthermore, the reference projects have shown that high relative humidity ( $RH > 80\%$ ) by itself, is not a threat to moisture safety goals, unless additional direct water contact appears and is not treated or removed; here the overall rainfall being more important than intensity. Nevertheless, high-moisture risk regions, such as, horizontal floor elements, gaps or floor-wall joints, always require further precaution, while adhesives have a minor role in the wetting performance.

The following summarized conclusions should be considered after manufacturing, during transport and construction:

- *Prefabrication;*

Reduce on-site exposure time by minimal storage time and minimize situations, such as, weather wetting hazards and rainy periods. Although crucial, short building times require precaution, mainly because of the drying potential - drying rates are lower than wetting rates, even under ventilated conditions.

- *Weather protection;*

Controlled climate, if applicable is always better than any other wetting protection. Wraps and tarps should be placed in a controlled environment, presumably in a factory, properly stored and left on the product until assembly. Although, the cost of different levels of protection is

not assessed, it might be important to the investor. At the same time, higher cost and protection could lead to safer construction and increased productivity.

- *Moisture control;*

The initial MC, or delivery MC values should be in accordance with the expected final MC. Although, wetting is quick, drying takes time, particularly in case of inner moisture. Regular inspections of surface and average MC throughout storage and after assembly, especially high-risk locations, such as, joints, cracks, and wall to floor connections. Moreover, during wetting gaps and crack are crucial, but CLTs' and Glulams' end-grains behavior and water uptake deserves special care.

Finally, according to this study it was found that construction with engineered wood products especially, CLT and Glulam structures, without temporary roof protection in high risky-wet climates, is considered possible. However, the on-site moisture safety principles must be strictly followed, with an additional accurate pre-planning of the moisture management agenda.

## 7.2 Recommendations

The recommendations listed below should be followed and considered during construction with EWP:

- Detailed planning in order to reduce building time and increase prefabrication.
- Demand maximum MC of products upon delivery, according to final expected MC.
- Protect products from exposure and moisture during transport, handling and erection. Appropriate and ventilated on-site storage is essential to reduce moisture risks.
- Immediately clean any liquid water found on the surface; if snow clear before melted. Additionally, if necessary, promote drying with artificial construction heaters or fans.
- Regular MC measurements at any depth (average and surface) in different random locations, from delivery till enclosure and after. The greatest protection is, if maximum MC values are not exceeded.
- Continuous control in high-risk moisture locations. Water can easily penetrate in cracks and joints, use protection tape if needed.
- Although in recent projects, temporary roof cover is considered troublesome, it is still safer than no-cover. Consider wind loads, assembly time and additional costs, if temporary roof, in the preparation phase, is found to be necessary.

### 7.3 Further work

- Observed high moisture risk locations, in the *Skipet* project, such as; gaps-cracks between elements lamellas, CLT wall elements and concrete/CLT floor connections and CLT floor and cement screed top, require further study and assessment, with experiments incorporated with the measured data.
- Regardless of the fact, that no visible damage was found, the unusual stains observed on the horizontal CLT floor elements in the *Skipet* project should be checked for mould appearance and if the upper or safe MC value is exceeded, with a hand-held moisture meter.
- Additional knowledge and research in water migration and its behaviour in CLT structure subject to fibre orientation is relevant to be examined into details.
- Further CLT data experiments, in order to diminish regulations from sawn timber and similar products to be dominant into practice. As an example, the impact of adhesives on moisture behaviour of CLT panels.

## 8. References

- [1] Zukunftsinstitut Österreich GmbH (2017). The future of timber construction – CLT [pdf]. Available: <https://www.clt.info/wp-content/uploads/2017/06/Stora-Enso-The-future-of-timber-construction-EN.pdf> [Accessed 14.03.2019]
- [2] Max Smyth (2018). A Study of the Viability of Cross Laminated Timber for Residential Construction. [pdf]. Available: <https://pdfs.semanticscholar.org/7c0e/43d87ce23a8eb28f13528407bb304c315490.pdf> [Accessed 14.03.2019]
- [3] TUOMAS.H, LAURA.S, SAMPO.S, KIM.P and TIINA.P (2013). Approaches for inclusion of forest carbon cycle in life cycle assessment – a review. Available: <https://onlinelibrary.wiley.com/doi/full/10.1111/gcbb.12016> [Accessed 14.03.2019]
- [4] Swedish Forest Industries Federation - Swedish Wood (2016). Design of timber structures vol.1 [pdf], pp.29-64. Available: [https://www.swedishwood.com/publications/list\\_of\\_swedish\\_woods\\_publications/design-of-timber-structures/](https://www.swedishwood.com/publications/list_of_swedish_woods_publications/design-of-timber-structures/) [Accessed 18.03.2019]
- [5] rethink Wood. Mass Timber in North America – Expanding the possibilities of wood building design [pdf]. Available: <https://www.awc.org/pdf/education/des/ReThinkMag-DES610A-MassTimberinNorthAmerica-161031.pdf> [Accessed 18.03.2019]
- [6] Build Smart a construction productive magazine (2017). WHAT IS MASS ENGINEERED TIMBER CONSTRUCTION? – article [pdf]. Available: [https://www.bca.gov.sg/Publications/BuildSmart/others/buildsmart\\_17issue35.pdf](https://www.bca.gov.sg/Publications/BuildSmart/others/buildsmart_17issue35.pdf) [Accessed 18.03.2019]
- [7] Hans Joachim, B. and Carmen, S. (2017). Timber Engineering - Principles for Design. Karlsruher Institut für Technologie (KIT): KIT Scientific Publishing, pp.21-35.
- [8] FPIInnovations and Binational Softwood Lumber Council (2013). CLT Handbook. 570 boul St.Jean: Pointe-Claire, QC. Available: [https://www.thinkwood.com/wp-content/uploads/2017/12/CLT\\_USA-Complete-document-Think\\_Wood.pdf](https://www.thinkwood.com/wp-content/uploads/2017/12/CLT_USA-Complete-document-Think_Wood.pdf) [Accessed 21.03.2019]
- [9] Lucas Epp (2018). Dowel Laminated Timber. *Wood design building*, [Online]. Available: <http://www.wooddesignandbuilding.com/dowel-laminated-timber/> [Accessed 26.03.2019]
- [10] Hans Joachim, B. and Carmen, S. (2017). Timber Engineering - Principles for Design. Karlsruher Institut für Technologie (KIT): KIT Scientific Publishing, pp.37-53.
- [11] Swedish Forest Industries Federation - Swedish Wood (2016). Design of timber structures vol.1 [pdf], pp. 258-267. Available: [https://www.swedishwood.com/publications/list\\_of\\_swedish\\_woods\\_publications/design-of-timber-structures/](https://www.swedishwood.com/publications/list_of_swedish_woods_publications/design-of-timber-structures/) [Accessed 27.03.2019]
- [12] FPIInnovations and Binational Softwood Lumber Council (2013). CLT Handbook. 570 boul St.Jean: Pointe-Claire, QC. Available: [https://www.thinkwood.com/wp-content/uploads/2017/12/CLT\\_USA-Complete-document-Think\\_Wood.pdf](https://www.thinkwood.com/wp-content/uploads/2017/12/CLT_USA-Complete-document-Think_Wood.pdf) [Accessed 27.03.2019]
- [13] Robert T.M. Lepage (2012). Moisture Response of Wall Assemblies of Cross-Laminated Timber Construction in Cold Canadian Climates, pp.24-37 [pdf]. Available: [https://www.researchgate.net/publication/266891766\\_Moisture\\_Response\\_of\\_Wall\\_Assemblies\\_of\\_Cross-Laminated\\_Timber\\_Construction\\_in\\_Cold\\_Canadian\\_Climates](https://www.researchgate.net/publication/266891766_Moisture_Response_of_Wall_Assemblies_of_Cross-Laminated_Timber_Construction_in_Cold_Canadian_Climates) [Accessed 27.03.2019]

- [14] Stora Enso Division Wood Products. CLT Technical brochure [pdf]. Available: <https://www.clt.info/wp-content/uploads/2017/09/Technical-brochure-CLT-EN.pdf> [Accessed 27.03.2019]
- [15] Swedish Forest Industries Federation - Swedish Wood (2016). Design of timber structures vol.1 [pdf], pp.57-65 123. Available: [https://www.swedishwood.com/publications/list\\_of\\_swedish\\_woods\\_publications/design-of-timber-structures/](https://www.swedishwood.com/publications/list_of_swedish_woods_publications/design-of-timber-structures/) [Accessed 06.04.2019]
- [16] Hans Joachim, B. and Carmen, S. (2017). Timber Engineering - Principles for Design. Karlsruher Institut für Technologie (KIT): KIT Scientific Publishing, pp.99-133
- [17] Robert T.M. Lepage (2012). Moisture Response of Wall Assemblies of Cross-Laminated Timber Construction in Cold Canadian Climates, pp.22 [pdf]. Available: [https://www.researchgate.net/publication/266891766\\_Moisture\\_Response\\_of\\_Wall\\_Assemblies\\_of\\_Cross-Laminated\\_Timber\\_Construction\\_in\\_Cold\\_Canadian\\_Climates](https://www.researchgate.net/publication/266891766_Moisture_Response_of_Wall_Assemblies_of_Cross-Laminated_Timber_Construction_in_Cold_Canadian_Climates) [Accessed 06.04.2019]
- [18] Öberg J. and Wiege E. (2018). Moisture risks with CLT-panels subjected to outdoor climate during construction -focus on mould and wetting processes [pdf]. Available: <http://kth.diva-portal.org/smash/record.jsf?pid=diva2%3A1222631&dswid=-3903> [Accessed 07.04.2019]
- [19] S.L. Zelinka, S. Kordzieib, S. Peib, S.V. Glass, P.C. Tabares-Velasco (2018). Moisture monitoring throughout the construction and occupancy of mass timber buildings [pdf]. Available: [https://www.fpl.fs.fed.us/documnts/pdf2018/fpl\\_2018\\_zelinka003.pdf](https://www.fpl.fs.fed.us/documnts/pdf2018/fpl_2018_zelinka003.pdf) [Accessed 11.04.2019]
- [20] Jeleč M., Varevac D. and Rajčić V. (2018). Cross-laminated timber (CLT) – a state of the art report. Available: [https://www.researchgate.net/publication/324441478\\_Cross-laminated\\_timber\\_CLT\\_-\\_A\\_state\\_of\\_the\\_art\\_report](https://www.researchgate.net/publication/324441478_Cross-laminated_timber_CLT_-_A_state_of_the_art_report) [Accessed 19.04.2019]
- [21] Wang, J. (2016). Guide for On-site Moisture Management of Wood Construction [pdf]. Available: <https://www.bchousing.org/publications/Wood-Construction-Moisture-Management-Guide> [Accessed 19.04.2019]
- [22] Liisma, E., Kolomees, T., Kuus, B.L. and Kukk, V. (2019). A case study on construction of CLT building without preliminary roof [pdf]. Available: [https://www.taltech.ee/public/k/Konverentsikeskus/A\\_case\\_study\\_on\\_construction\\_of\\_CLT\\_building\\_without\\_preliminary\\_roof.pdf](https://www.taltech.ee/public/k/Konverentsikeskus/A_case_study_on_construction_of_CLT_building_without_preliminary_roof.pdf) [Accessed 30.04.2019]
- [23] Dietsch, P., Franke, S., Franke, B., Gamper, A. and Winter, S. (2015). Methods to determine wood moisture content and their applicability in monitoring concepts [pdf]. Available: <https://link.springer.com/article/10.1007/s13349-014-0082-7> [Accessed 30.04.2019]
- [24] Giovanni Luciani (2017). Impact of moisture content of wood lamellae to the air- permeability of cross laminated timber [pdf]. Available: <https://digi.lib.ttu.ee/i/?9765> [Accessed 30.04.2019]
- [25] Gransberger, E. and Hinton, L. (2018). Know the risks of cross-laminated timber before beginning your project [pdf]. Available: <https://www.bizjournals.com/portland/news/2018/09/11/know-the-risks-of-cross-laminate-timber-before.html> [Accessed 30.04.2019]
- [26] Dujič, B. (2013). Konstrukcije iz križno lepljenih lesenih panelov – Nova pot sodobnega gradbeništva [pdf]. Available: <http://www.cbd.si/katalogi-s/680-nova-pot-sodobnega-gradbenistva> [Accessed 01.05.2019]

- [27] Zurich Insurance Group Ltd. (2018). Cross Laminated Timber Panels in Construction [pdf]. Available: <https://insider.zurich.co.uk/app/uploads/2018/05/Risk-Topic-1.pdf> [Accessed 01.05.2019]
- [28] J. Y. Wang, R. Stirling, Paul I. Morris and A. Taylor (2018). Durability of mass timber structures: A review of the biological risks [pdf]. Available: <https://pdfs.semanticscholar.org/ec73/2410f6a85ad3176cbadf96690854b13b42fd.pdf> [Accessed 02.05.2019]
- [29] Rune B. Abrahamsen and Kjell A. Malo (2014). STRUCTURAL DESIGN AND ASSEMBLY OF “TREET” [pdf]. Available: [http://www.lignum.ch/editor/images/Downloads\\_deutsch/Treet\\_Abrahamsen.pdf](http://www.lignum.ch/editor/images/Downloads_deutsch/Treet_Abrahamsen.pdf) [Accessed 02.05.2019]
- [30] Rune Abrahamsen (2017). Mjøstårnet – Construction of an 81 m tall timber building. *Internationales Holzbau-Forum IHF* [pdf]. Available: <https://www.moelven.com/globalassets/moelven-limtre/mjostarnet/mjostarnet---construction-of-an-81-m-tall-timber-building.pdf> [Accessed 03.05.2019]
- [31] Evan L. Schmidt, Mariapaola Riggio and Andre R. Barbosa (2019). Environmental response of a CLT floor panel- Lessons for moisture management and monitoring of mass timber buildings [pdf]. Available: <https://www.researchgate.net/publication/329330278> [Accessed 03.05.2019]
- [32] Evan L. Schmidt, Mariapaola Riggio, Paul F. Laleicke, Andre R. Barbosa and Kevin V. Wymelenberg (2017). How monitoring clt buildings can remove market barriers and support designers in North America- Introduction to preliminary environmental studies [pdf]. Available: <http://www.scantronik.de/Publikationen/Materialfeuchte%20Gigamodul%20-%20Datenlogger%20-%20Publikation%2063100.pdf> [Accessed 04.05.2019]
- [33] Silva, C., Brancol, J. and Lourenco, P. (2016). Strategies to avoid humidity causing damages in tall timber buildings [pdf]. Available: <https://www.researchgate.net/publication/310160437> [Accessed 05.05.2019]
- [34] Eikeskog, E., Sørebo, H. and Johnsen, K. (2018). *Livsløpsanalyse av yrkesbygg i massivtre*. I hvilken grad vil massivtre bidra til reduserte CO2-utslipp? [pdf] Bergen: HVL Bacheloroppgave i Energiteknologi
- [35] Günther Jauk, translation by Susanne Höfler (2018). CLT market keeps growing briskly. Timber – Online, [online]. Available: <https://www.timber-online.net/holzprodukte/2018/11/CLT-production-2017-growing-market.html> [Accessed 05.05.2019]
- [36] CBD d.o.o. (2015). Types of timber structures [online]. Available: <http://www.cbd.si/en/timber-structures/types-of-timber-structures> [Accessed 05.05.2019]
- [37] Swedish Forest Industries Federation - Swedish Wood (2016). Design of timber structures vol.3 [pdf], pp.7 Available: [https://www.swedishwood.com/publications/list\\_of\\_swedish\\_woods\\_publications/design-of-timber-structures/](https://www.swedishwood.com/publications/list_of_swedish_woods_publications/design-of-timber-structures/) [Accessed 18.04.2019]
- [38] Think Wood (2019). Taller wood buildings [online]. Available: <https://www.thinkwood.com/building-better/taller-buildings> [Accessed 07.05.2019]
- [39] David Barber (2015). Tall Timber Buildings: What’s Next in Fire Safety [pdf]. Available: <https://www.researchgate.net/publication/278724375> [Accessed 08.05.2019]
- [40] Diego Peñaloza (2015). Exploring climate impacts of timber buildings-*The effects from including non-traditional aspects in life cycle climate impact assessment* [pdf]. Stockholm: KTH - Department of Civil and Architectural Engineering. Available: <http://www.diva-portal.org/smash/record.jsf?pid=diva2%3A793941&dswid=-9774> [Accessed 10.05.2019]

- [41] C. Demirci, C. Málaga-Chuquitaype and L. Macorini (2017). Seismic behavior and design of tall Cross-Laminated timber buildings [pdf]. Available: <https://www.researchgate.net/publication/311065666> [Accessed 08.05.2019]
- [42] Miha Humar (2009). Kako zaščititi les?. *Lesena gradnja* [pdf]. Available: [http://www.lesena-gradnja.si/html/img/pool/Kako\\_za\\_iti\\_les\\_Humar.pdf](http://www.lesena-gradnja.si/html/img/pool/Kako_za_iti_les_Humar.pdf) [Accessed 10.05.2019]
- [43] Milan Šrenek (2009). Konstrukcijski kompozitni les. *Lesena gradnja* [pdf]. Available: <http://www.lesena-gradnja.si/html/pages/si-clanki-materijal-tehnologija-konstrukcijski-kompozitni-les.htm> [Accessed 10.05.2019]
- [44] Kristine Nore (2017). Wood moisture [pdf]. Available: <http://www.treteknisk.no/resources/filer/aktuelt/4-Kristine-Nore.pdf> [Accessed 10.05.2019]
- [45] Ostman, B., Schmid, J., Klippel, M., Alar, J., Werther N. and Brandon, D. (2018). Fire design of clt in Europe. *Journal of the Society of Wood Science and Technology* [pdf]. Available: <https://www.researchgate.net/publication/322991972> [Accessed 11.05.2019]
- [46] Stora Enso Division Wood Products. Wood: the world's oldest and yet most modern building material – Brochure [pdf]. Available: [https://issuu.com/storaenso/docs/stora\\_enso\\_clt\\_-\\_wood\\_the\\_world\\_\\_s](https://issuu.com/storaenso/docs/stora_enso_clt_-_wood_the_world__s) [Accessed 12.05.2019]
- [47] Lepage, R., Higgins, J. and Finch, G. (2016). Moisture uptake testing for clt floor panels in a tall wood building in Vancouver. *RDH Building Science Inc.* [pdf]. Available: <https://buildingsciencelabs.com/wp-content/uploads/2017/11/CCBST-2017-Moisture-Uptake-Testing-for-CLT-Floor-Panels.pdf> [Accessed 13.05.2019]
- [48] Erstad, M., Ivarsoy, B., Knutsen, T. B. and Torsvik, L. O. (2018). Hybrid Solutions in Office Building [pdf]. Bergen: HVL Bacheloroppgave - Avdeling for ingeniør- og økonomifag Bygg.
- [49] Ahvenainen, J. and Sousa, H. S. (2016). Multistorey building made of CLT- How to design it right? [pdf]. Available: <https://www.researchgate.net/publication/311558471> [Accessed 05.05.2019]
- [50] Institute of Timber Engineering and Wood Technology -holzbau forschungs gmbh, Graz university of technology (2012). The seismic behavior of buildings erected in solid timber construction. *Seismic design according to EN 1998 for a reference building in clt* [pdf]. Graz: Stora Enso. Available: <https://www.clt.info/wp-content/uploads/2015/10/The-seismic-behaviour-of-buildings-erected-in-Solid-Timber-Construction-EN.pdf>
- [51] Novak, W. M., Koppelhuber, J. and Pock, K. (2014). Cross-Laminated Timber Structural Design [pdf] Vienna: proHolz Austria. Available: [https://www.binderholz.com/fileadmin/PDF/Basisprodukte/Brettsperholz\\_BBS/201411\\_proHolz\\_Cross-Laminated\\_Timber\\_Structural\\_Design.pdf](https://www.binderholz.com/fileadmin/PDF/Basisprodukte/Brettsperholz_BBS/201411_proHolz_Cross-Laminated_Timber_Structural_Design.pdf)
- [52] StructurLam (2017). Clt technical design guide [pdf]. Available: <http://www.structurlam.com/wp-content/uploads/2016/10/CrossLam-CLT-CA-Design-Guide-1.pdf> [Accessed 15.05.2019]
- [53] UN department of economics and social affairs. World Urbanization Prospects 2018. *68% of the world population projected to live in urban areas by 2050* [online]. Available: <https://www.un.org/development/desa/en/news/population/2018-revision-of-world-urbanization-prospects.html> [Accessed 17.05.2019]
- [54] University of Waikato (2007). Water molecule - Article [online]. Available: <https://www.sciencelearn.org.nz/images/1136-water-molecule> [Accessed 17.05.2019]



- [55] Autodesk (2018). Psychrometric Charts Part-1 [online]. Available: <https://knowledge.autodesk.com/support/revit-products/getting-started/caas/simplecontent/content/psychrometric-charts-part-1.html> [Accessed 17.05.2019]
- [56] Straube, J., & Burnett, E. (2005). *Building Science for Building Enclosures*. Westford, Massachusetts: Building Science Press Inc.
- [57] Care for wood. Wood Anatomy- Cellular structure [online]. Available: <https://careforwood.wordpress.com/wood-anatomy/> [Accessed 17.05.2019]
- [58] Swedish Wood – Mikael Eliasson. Moisture Content [online]. Available: [https://www.swedishwood.com/about\\_wood/choosing-wood/wood-and-moisture/](https://www.swedishwood.com/about_wood/choosing-wood/wood-and-moisture/) [Accessed 14.05.2019]
- [59] Kumaran, M.K. 2002. A thermal and moisture property database for common building and insulation Materials - report [pdf], Project 1018-RP
- [60] GC-Rieber Eiendom. Bergens første og største næringsbygg i massivtre, [online]. Available: <https://www.gcrieber-eiendom.no/aktuelt/vi-bygger-bergens-foerste-og-stoerste-naeringsbygg-i-massivtre/> [Accessed 17.05.2019]
- [61] Rune Abrahamsen (2018). Mjøstårnet - 18 storey timber building completed. 24 *Internationales Holzbau-Forum IHF* [pdf]. Available: <https://www.moelven.com/globalassets/moelven-limtre/mjostarnet/mjostarnet---18-storey-timber-building-completed.pdf> [Accessed 17.05.2019]
- [62] The Tree ("Treet") - The tallest wooden house in the world. (2015). Norway: filmtriks [video]. Available: <https://www.bob.no/treet/treet-info-in-english> [Accessed 17.05.2019]
- [63] Ole Herbrand Kleppe. (2015). Construction of Treet – How and why [pdf]. Bergen: BOB. Available: <https://www.bob.no/treet/treet-presentasjoner> [Accessed 17.05.2019]
- [64] Ole Herbrand Kleppe. (2015). The Construction of TREET – How did we do it? [pdf]. Bergen: BOB. Available: <https://www.bob.no/treet/treet-presentasjoner> [Accessed 17.05.2019]